

Pressure Vessel

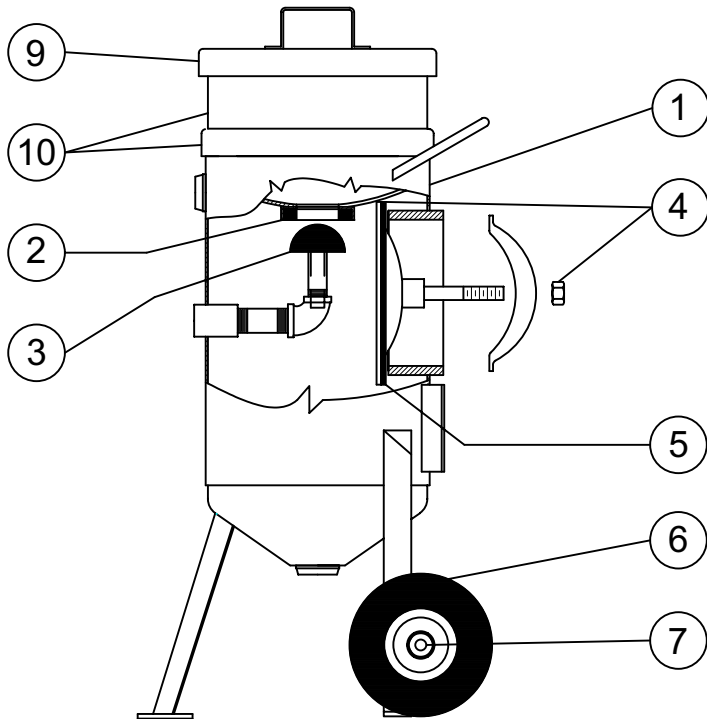

④ ⑤ Vessels made before October, 1995 may have 4" x 6" Handway.
 4" x 6" handway assembly with gasket Part No. 7000-000
 4" x 6" handway gasket Part No. 7000-000-06

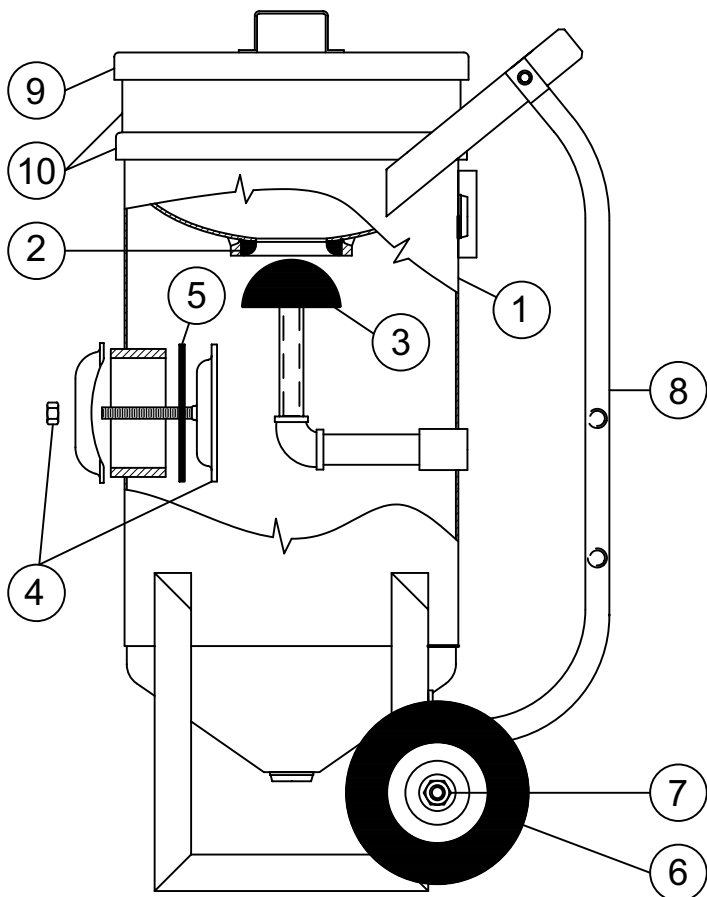

1.5 cu. ft Vessel		
No.	Part No.	Description
1.	1011-001-02	Portable Vessel
2.	2100-001	Pop Up Gasket
3.	2100-000	Pop Up with stem
4.	7000-001-11	Handway Assembly, 6" x 8" with gasket
5.	7000-001-06	Gasket
6.	7046-002	Wheel
7.	7040-003 7019-519	Axle (as of April, '95) Nut, 3/4"
8.		Not Available
9.	5010-010	Lid (Optional)
10.	5011-010	Screen (Optional)

3.5 cu. ft Vessel		
No.	Part No.	Description
1.	1011-003-03 1011-003-04	Portable Vessel Stationary Vessel
2.	2100-011	Pop Up Gasket
3.	2100-010	Pop Up with stem
4.	7000-001-11	Handway Assembly, 6" x 8" with gasket
5.	7000-001-06	Gasket
6.	7046-003	Wheel
7.	7040-003 7019-519	Axle Nut, 3/4"
8.	7002-003	Load Skid (Optional)
9.	5010-030	Lid (Optional)
10.	5011-030	Screen (Optional)

6.5 cu. ft Vessel		
No.	Part No.	Description
1.	1011-003-03 1011-003-04	Portable Vessel Stationary Vessel
2.	2100-011	Pop Up Gasket
3.	2100-010	Pop Up with stem
4.	7000-001-11	Handway Assembly, 6" x 8" with gasket
5.	7000-001-06	Gasket
6.	7046-006	Wheel
7.	7040-006 7019-527	Axle Nut, 1"
8.	7002-006	Load Skid (Optional)
9.	5010-060	Lid (Optional)
10.	5011-060	Screen (Optional)

10 cu. ft Vessel		
No.	Part No.	Description
1.	1011-010-02 1011-010-03	Portable Vessel Stationary Vessel
2.	2100-011	Pop Up Gasket
3.	2100-010	Pop Up with stem
4.	7000-001-11	Handway Assembly, 6" x 8" with gasket
5.	7000-001-06	Gasket
6.	7046-006	Wheel
7.	7040-006 7019-527	Axle Nut, 1"
8.	7002-010	Load Skid (Optional)
9.	5010-060	Lid (Optional)
10.	5011-060	Screen (Optional)

20 cu. ft Vessel		
No.	Part No.	Description
1.	1012-020-03	Stationary Vessel
2.	2100-011	Pop Up Gasket
3.	2100-010	Pop Up with stem
4.	7000-001-11	Handway Assembly, 6" x 8" with gasket
5.	7000-001-06	Gasket
6.		Not Available
7.		Not Available
8.		Not Available
9.	5010-200	Lid (Optional)
10.	5011-200	Screen (Optional)