

| Item | Qty | Part No. | Description |
|------|-----|-------------|-----------------------------|
| 1 | 1 | 7010-515-12 | Hex Bolt, 5/8" UNC x 3 1/2" |
| 2 | 1 | 2149-000-02 | Cap |
| 3 | 1 | 2149-000-19 | Bump Ring |
| 4 | 1 | 2149-000-03 | Spring |
| 5 | 1 | 2149-000-08 | Nut |
| *6 | 1 | 2149-000-04 | Piston Seal |
| 7 | 1 | 2149-000-05 | Piston |
| *8 | 1 | 2149-000-07 | Tungsten Carbide Plunger |
| 9 | 1 | 2149-000-09 | Cylinder |
| *10 | 1 | 2149-000-06 | Plunger Seal |
| 11 | | | |
| 12 | | | |
| 13 | | | |
| *14 | 1 | 2149-009-35 | O-Ring |
| *15 | 1 | 2149-100-13 | Urethane Sleeve |
| 16 | 1 | 2149-407-11 | Direct Down Base |
| 17 | 4 | 7010-507-14 | Bolt, 3/8" UNC x 3 3/4" |
| 18 | 1 | 7027-552-02 | Flat Washer, 5/8" SAE |
| 19 | 1 | 7017-515 | Nut, 5/8" UNC |
| 20 | 4 | 7027-503-02 | Flat Washer, 3/8" SAE |
| 21 | 1 | 2149-000-16 | Sleeve Pin |

Note: * Indicates Items Included In Replacement Part Kit (2149-100-99)

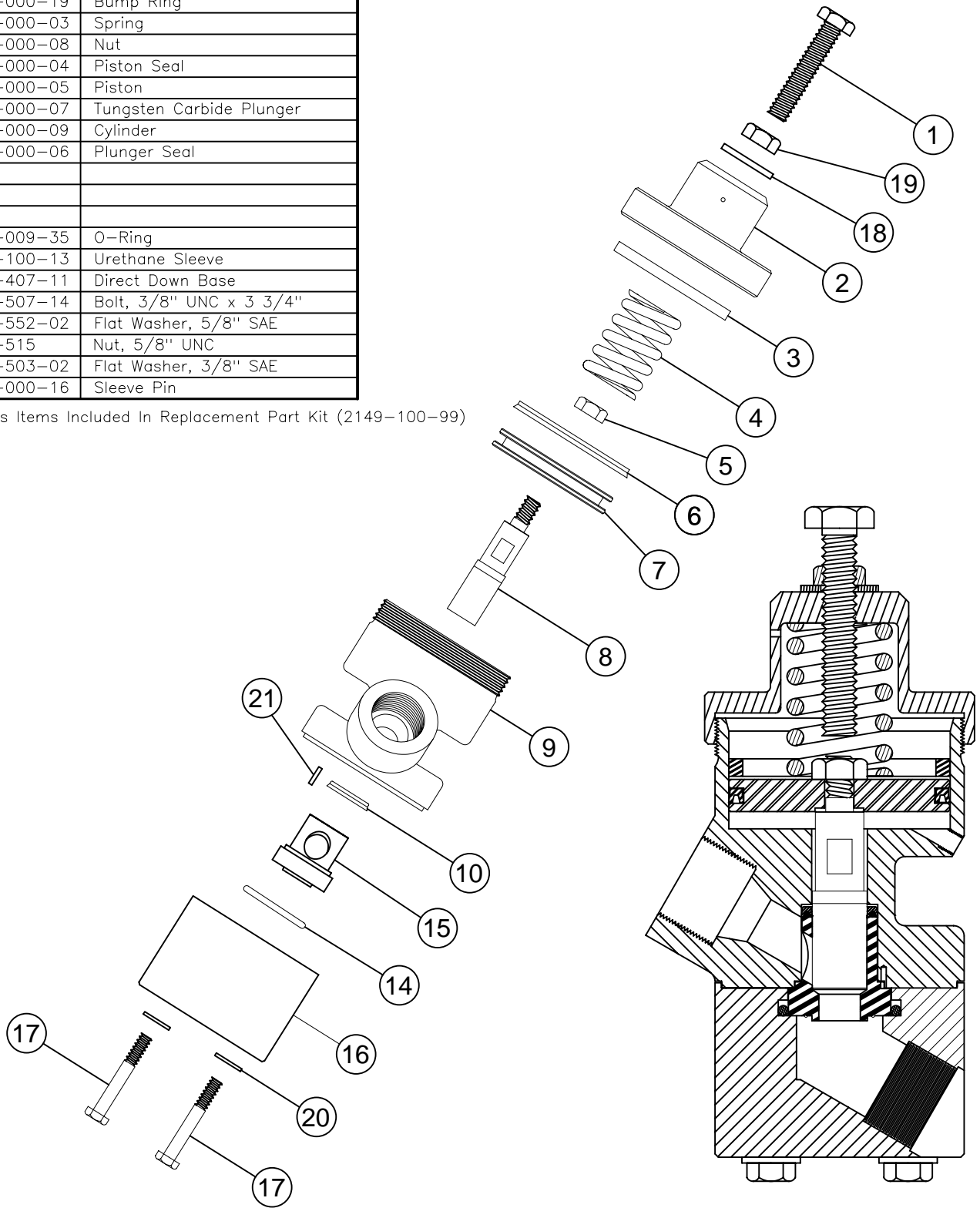

PROPRIETARY INFORMATION

DESIGN INFORMATION CONTAINED HEREIN IS PROPRIETARY AND CONFIDENTIAL AND THE EXCLUSIVE PROPERTY OF AXIOM MANUFACTURING, INC. NO PORTION OF ANY DESIGN INFORMATION CONTAINED HEREIN MAY BE USED BY, OR DISCLOSED TO UNAUTHORIZED PERSONNEL WITHOUT THE EXPRESSED WRITTEN CONSENT OF AXIOM MANUFACTURING, INC.

AXIOM MFG IS THE EXCLUSIVE MANUFACTURER OF SCHMIDT® PRODUCTS

AXIOM MANUFACTURING, INC.

SCALE: N.T.S.

DATE: 4/20/07

APPROVED BY:

DRAWN BY: JH

REVISED

THOMPSON VALVE DIRECT DOWN WITH URETHANE SLEEVE

REFERENCE NUMBER:

2151-100

PART/DRAWING NUMBER:

2151-100

| REV | DESCRIPTION | DATE | BY |
|-----|-------------|------|----|
| | | | |