

No.	Part No.	Description
	2152-100-99	Replacement Part Kit With Polyurethane Sleeve
1.	7010-515-12	Hex Bolt, 5/8" UNC x 3 1/2" Lg.
2.	2152-000-17	Breather Vent
3.	2152-000-12	Spring Retainer
4.*	2152-000-18	O-Ring
5.	7027-503-02	Washer
6.	7010-507-07	Hex Bolt, 3/8" UNC x 1-1/4" Lg.
7.	2152-000-02	Cap Plate
8.*	2152-000-16	Cap Gasket
10.	2152-000-25	Vibration Disc
11.	2152-000-03	Spring
12.	2149-000-08	Nut
13.*	2149-000-04	Piston Seal
14.	2152-000-05	Piston
15.*	2152-000-07	Tungsten Carbide Plunger
16.	2152-000-09	Cylinder
17.*	2152-000-06	Plunger Seal, 1-req'd (Purple Urethane)
18.*	2152-000-06	Plunger Seal, 2-req'd (Purple Urethane)
19.	2152-000-14	Body
21.	2152-307-15	Direct Down Base, 1 1/4" FNPT
22.	7010-507-12	Hex Bolt, 3/8" UNC x 3 1/2" Lg.
23.	3014-506	Plug
25.*	2152-100-13	Polyurethane Sleeve
26.	2149-000-16	Sleeve Pin
27.	2152-307-22	Direct Down Stud, 3/8" UNC x 4" Lg.
28.	7017-507	Hex Nut, 3/8" UNC
29.	7017-515	Hex Nut, 5/8" UNC
30.	7027-552-02	Flat Washer, 5/8"

* Included In Replacement Part Kit For Polyurethane Sleeve

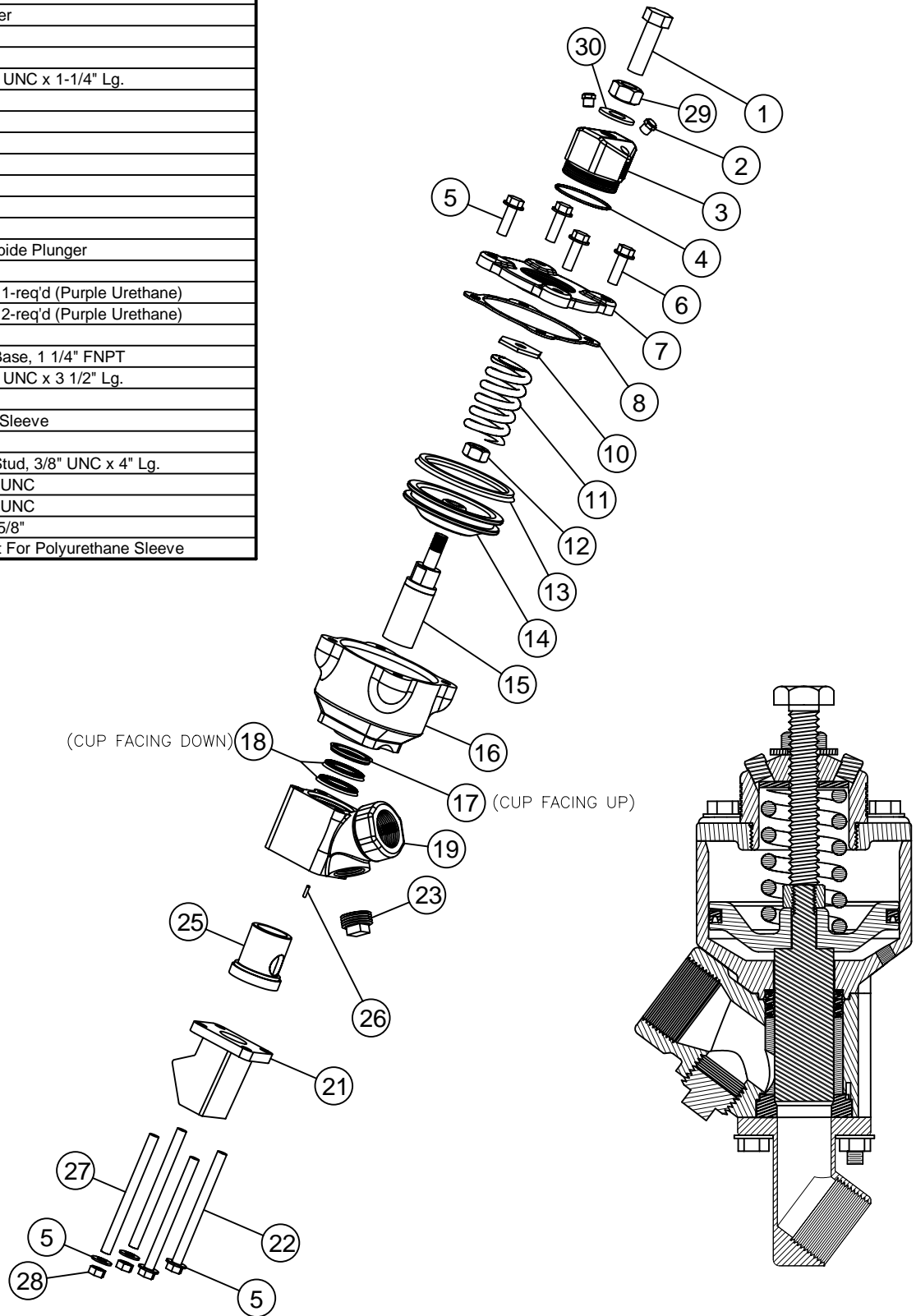

REV	DESCRIPTION	DATE	BY
B	ITEM 17 WAS 2149-500-06	11/15/07	JH
A	DELETED BUMP RING, REFER TO ECR S-0040	12/22/05	JH

SCHMIDT

SCALE: N.T.S.

DATE: 7/23/03

APPROVED

BY:

DRAWN BY: JH

REVISED

1 1/4" THOMPSON VALVE II DIRECT DOWN WITH POLYURETHANE SLEEVE

PART NUMBER:

2152-317

DRAWING NUMBER:

2152-317