

Item	Qty	Part No.	Description
1	1	2152-000-01	Knob
2	2	2152-000-17	Breather Vent
3	1	2152-000-12	Spring Retainer
*4	1	2152-000-18	O-Ring
5	8	7027-503-02	Washer
6	4	7010-507-07	Hex Bolt, 3/8" UNC x 1-1/4" Lg.
7	1	2152-000-02	Cap Plate
*8	1	2152-000-16	Cap Gasket
10	1	2152-000-25	Vibration Disc
11	1	2152-000-03	Spring
12	1	2149-000-08	Nut
*13	1	2149-000-04	Piston Seal
14	1	2152-000-05	Piston
*15	1	2152-000-07	Tungsten Carbide Plunger
16	1	2152-000-09	Cylinder
*17	1	2152-000-06	Plunger Seal, 1-req'd (Purple Urethane)
*18	2	2152-000-06	Plunger Seal, 2-req'd (Purple Urethane)
19	1	2152-000-14	Body
*20	1	2152-000-10	Seat
21	1	2152-000-19	Base, 1" NPT
22	4	7010-507-95	Hex Bolt, 3/8" UNC x 4 3/4" Lg.
23	1	3014-506	Plug
*24	1	2152-000-21	O-Ring
*25	1	2152-200-13	Carbide 2-Stage Slotted Sleeve
26	1	2149-000-16	Sleeve Pin

Note: \* Indicates Items Included In Replacement Part Kit

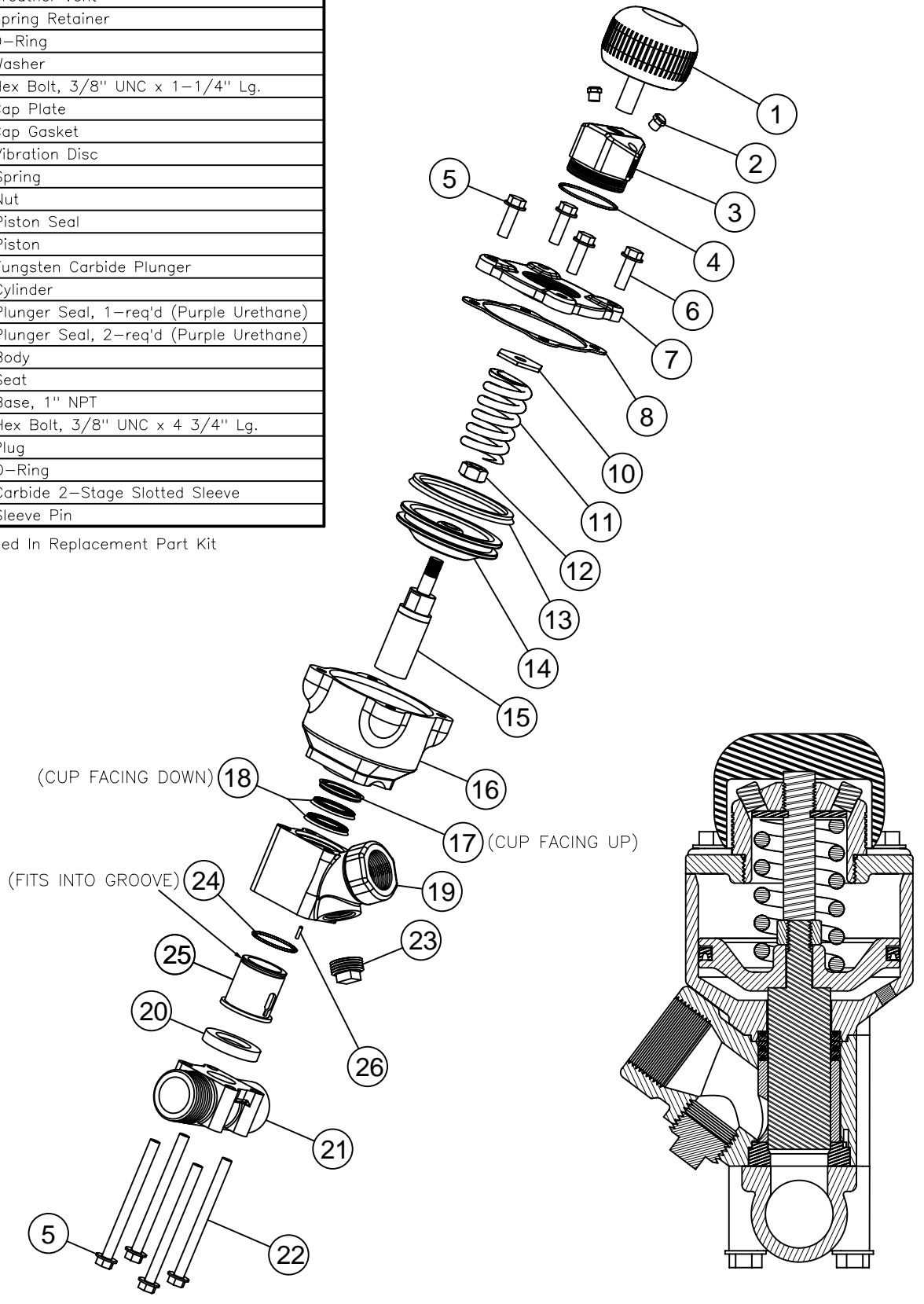

REV	DESCRIPTION	DATE	BY
B	ITEM 17 WAS 2149-500-06	11/15/07	JH
A	DELETED BUMP RING, REFER TO ECR S-0040	12/22/05	JH

SCHMIDT

SCALE: N.T.S.	APPROVED BY:	DRAWN BY: JH
DATE: 7/23/03		REVISED
1" THOMPSON VALVE II WITH TUNGSTEN CARBIDE SLOTTED SLEEVE		
PART NUMBER: 2152-216	DRAWING NUMBER: 2152-216	