

# G2 PNEUMATIC DEADMAN

OPERATION AND MAINTENANCE MANUAL

AUGUST 2006



SAVE THIS MANUAL AND MAKE AVAILABLE  
TO ALL USERS OF THIS EQUIPMENT!

Manual Part Number 7200-280



AXXIOM Manufacturing, Inc.  
11927 S. Highway 6, Fresno, Texas 77545  
800.231.2085 \* 281.431.0581 \* fax 281.431.1717



# WARNING

- 1. Any person intending to operate this equipment or any person intending to be in the vicinity during its operation that cannot read or completely understand all of the warnings, operating procedures and instructions, and the rules for safer operation contained in this manual must receive proper training from their supervisor and/or employer. Consult Axxiom Manufacturing, Inc.**
- 2. Do not operate any abrasive blaster or blast equipment before reading and completely understanding all the warnings, operating procedures and instructions, and the rules for safer operation contained in this manual.**
- 3. Do not operate any abrasive blaster or blast equipment without following the rules for safer operation and all the operating procedures and instructions. Failure to properly use blast equipment could result in serious injury or death.**
- 4. Do not perform any maintenance while any abrasive blaster or blast equipment is pressurized. Always depressurize any vessel before loading media or performing any maintenance.**
- 5. Do not use abrasives containing free silica. Silica can cause silicosis or other related respiratory damage. You must wear personal protective equipment for all abrasive blasting operations. Observe all applicable local, state and federal safety regulations in conjunction with airline filters and respiratory protection. Reference OSHA (Occupational Safety and Health Administration).**
- 6. Do not enter areas during abrasive blasting operations without breathing protection. All personnel in the vicinity of abrasive blasting operations should wear NIOSH approved air fed respirators, hoods or helmets.**
- 7. Do not modify or alter any abrasive blaster, blast equipment or controls thereof without written consent from Axxiom Manufacturing, Inc.**
- 8. Do not use bleeder type deadman valves on any Schmidt® abrasive blasters. The use of A-BEC, Clemco or a similar bleeder type deadman valve can cause unintentional start-up without warning, which can result in serious personal injury.**
- 9. Do not sell, rent, or operate abrasive blasters without remote controls. OSHA regulations require remote controls on all blast machines. Failure to use remote controls can cause serious injury or death to the operator(s) or other personnel in the blasting area. (Reference OSHA regulations.)**
- 10. Do not repair or replace any portion of Schmidt equipment using components that are not Schmidt original replacement parts. Use of replacement components that are not Schmidt original replacement parts may result in equipment failure which can result in serious personal injury and will void all warranties.**

G2 PNEUMATIC DEADMAN		
Item	Part No.	Description
	2263-002-99	G2 Replacement Parts Kit
1.	2263-002-01	G2 Deadman Lever
2.	2263-002-02	G2 Deadman Body
*3.	2263-002-03	G2 Deadman Cartridge Assembly
4.	2263-002-04	G2 Deadman Hinge Pin
*5.	2263-002-05	G2 Deadman Cartridge Set Screw
6.	2263-002-06	G2 Deadman Button
*7.	2263-002-07	Deadman Spring
*8.	2263-000-08	Deadman Screw For Button
9.	3031-300-00	Hex Nipple, 1/8" x 1/8" With Ball Seat
10.	3031-302-02	Hex Nipple, 1/4" x 1/4" With Ball Seat
* Items included in Replacement Kit		

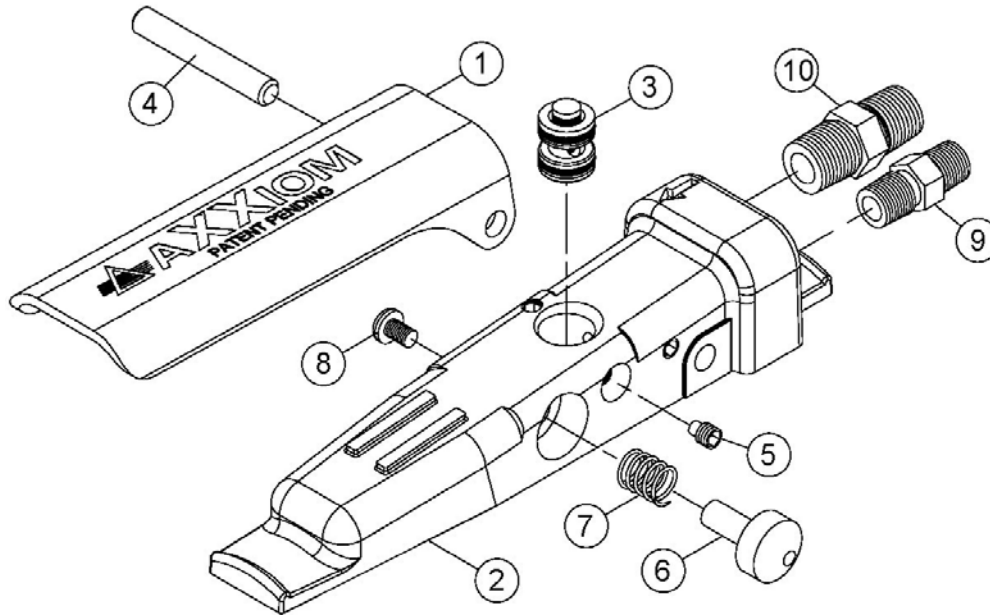

## 1.0. RULES FOR SAFER OPERATION

- 1.1. **KNOW YOUR EQUIPMENT.** Do Not operate this equipment in a manner other than its intended application (see Section 2.0). Do Not operate this equipment without following the *Rules for Safer Operation* and all the operating procedures. Failure to do so could result in serious injury or death.
- 1.2. **RECEIVE PROPER TRAINING.** Do Not operate or perform maintenance on this equipment unless you have received operational and maintenance training. Begin by thoroughly reading and understanding this document and any operational and maintenance manual or instructions for the equipment that will be used in conjunction with the G2 Deadman. Consult an authorized Schmidt® or Axxiom distributor.
- 1.3. **USE PROPER PERSONAL PROTECTIVE EQUIPMENT.** Do Not operate or perform maintenance on this equipment without wearing OSHA approved eye, ear, foot, and lung protection.
- 1.4. **ADHERE TO ALL REGULATIONS.** Do Not operate or perform maintenance on this equipment without observing all local, state, and federal safety regulations including, but not limited to, OSHA (Occupational Health and Safety Administration).
- 1.5. **USE CORRECT REPLACEMENT PARTS.** Do Not use replacement parts that are not manufactured by Axxiom Manufacturing, Inc. and furnished by an authorized distributor of Axxiom Manufacturing, Inc. Incorrect replacement parts can result in equipment failure and cause serious injury or death.
- 1.6. **SAVE THIS OPERATION AND MAINTENANCE MANUAL.** Refer to this operation and maintenance manual as well as any other manufacturers information included for equipment that is used in conjunction with the G2 deadman. Never permit anyone to operate this equipment without having him/her first read this manual and receive proper training. Provisions should be made to have this manual readily available to the operating and maintenance personnel. If for any reason the manual becomes lost or illegible, have it replaced immediately. This operation and maintenance manual should be read periodically to maintain the highest skill level; it may prevent a serious accident.

## 2.0 GENERAL INFORMATION

- 2.1 The G2 Deadman is designed to be used in an abrasive blast control system as a device that allows remote control of the on-off function of the blast operation. Consult an authorized Axxiom distributor for system compatibility verification.
- 2.2 The G2 Deadman requires a clean air supply of a minimum of 55psig for proper operation of blast system components.

### **3.0 DISASSEMBLY (refer to drawing on facing page)**

(Tools required: hammer, dowel punch, phillips screwdriver, 3/32" allen wrench, 7/16" and 9/16" wrench, and pliers)

- 3.1 Remove the hinge pin (#4) and lever (#1).
- 3.2 Remove the button screw (#8).
- 3.3 Remove the spring (#7) and button (#6) from the deadman body (#2).
- 3.4 Remove the set screw (#5).
- 3.5 Remove the cartridge (#3) from the deadman body.
- 3.6 Do not remove any screw plugs from the deadman body.
- 3.7 Discard the old cartridge (#3), set screw (#5), spring (#7), and button screw (#8).

### **4.0 REASSEMBLY**

- 4.1 Clean deadman body (#2) removing all debris from the button and cartridge cavities.
- 4.2 Check deadman body for cracks or other defects. Inspect cartridge cavity for surface defects. Replace if necessary.
- 4.3 Inspect the new cartridge (#3) for presence of both o-rings and center spool.
- 4.4 Insert cartridge (#3) into the deadman body bevel end first. Push until the cartridge bottoms.
- 4.5 Install set screw (#5) to lock cartridge in place. Tighten firmly, but do not over tighten.
- 4.6 Place spring (#7) over the button shank (#6).
- 4.7 Fit the button with spring into the cavity of the deadman body (from either side for left or right hand operation).
- 4.8 Install button screw (#8) into the end of the button shaft (#6). Tighten firmly, but do not over tighten.
- 4.9 Measure the deadman lever (#1) for distortion. It should be 1-3/8" ear to ear. Place lever over the body lining up the holes.
- 4.10 Maintaining the hole alignment, hammer the hinge pin (#4) through the lever and body until centered.
- 4.11 Proceed to section 5.0 for installation instructions.

### **5.0 INSTALLATION**

- 5.1 The G2 Deadman works in junction with a twinline hose assembly. The twinline hose assembly consists of two color coded 3/16" air lines. The air supply line is orange and the signal/vent line is black. Each hose contains a male flared swivel fitting on one end and a female flared rigid fitting at the other. The supply line of the twinline has 1/4" fittings, and the signal/vent line has 1/8" fittings. The G2 deadman has matching 1/8" and 1/4" male fittings. It is important that the hoses have the correct sized fittings to prevent the deadman valve from being installed incorrectly. Connecting the air supply to the incorrect port of the G2 deadman will prevent the signal from venting and will not allow the blast operation to stop when the deadman valve is released.



Incorrect connection of the twinline hose to the G2 deadman can result in the inability to stop the blast operation which can result in serious injury or death.

- 5.2 Disconnect the twinline hose from the blast system and remove the existing deadman from the twinline.
- 5.3 Connect the 1/4" swivel fitting of the twinline to the 1/4" male pipe thread on the G2 deadman. No thread sealer is required since the fittings are flared. The opposite end of the twinline should be connected to the air supply of the blast system. Note the arrow molded into the body of the G2 deadman which indicates the air supply inlet flow direction into the deadman.
- 5.4 Connect the 1/8" swivel fitting of the twinline to the 1/8" male pipe thread on the G2 deadman. No thread sealer is required since the fittings are flared. The opposite end of this twinline hose is the signal air which starts the blast operation.
- 5.5 Follow the setup and pre-operating instructions provided with the blast system, then test the operation of the G2 deadman. Check for air leaks at all the connections repair as required.

### **6.0 MAINTENANCE AND INSPECTION**

- 6.1 Dirty air supply and/or back flow situations can result in an accumulation of debris in the twinline and deadman. Periodically disassemble and clean the G2 deadman.
- 6.2 Excessive abrasive found in the deadman indicates problems in the blast control system. Follow the troubleshoot procedures included in the blaster operation and maintenance manual.

### **7.1 TROUBLESHOOTING**

- 7.1 Air leaks from the deadman body:
  - 1) Defective cartridge (replace cartridge).
  - 2) Twinline hose connected incorrectly (verify air supply connection to deadman 1/4" male fitting).
- 7.2 Blast outlet air and abrasive will not shut off when deadman lever is released:
  - 1) Twinline hose connected incorrectly (verify air supply connection to deadman 1/4" male fitting).
  - 2) Debris blocking flow in black signal/vent line (purge twinline hoses).
  - 3) Cartridge stuck in the "ON" position (defective cartridge or deadman body, inspect and/or replace)
- 7.3 Blast outlet start unintentionally:
  - 1) The deadman lever (1) is worn out (replace).
  - 2) The deadman button (#6) and/or spring (#7) is missing.
  - 3) Defective cartridge (missing or damaged o-rings, replace cartridge).
- 7.4 Blast outlet is slow to turn on or will not turn on when deadman lever is depressed:
  - 1) Debris blocking flow in black twinline signal/vent line (purge twinline hoses).
  - 2) Air leaks in twinline connections (tighten connections).
- 7.5 If problems persist, consult blaster operation and maintenance manual for further troubleshooting procedures.