

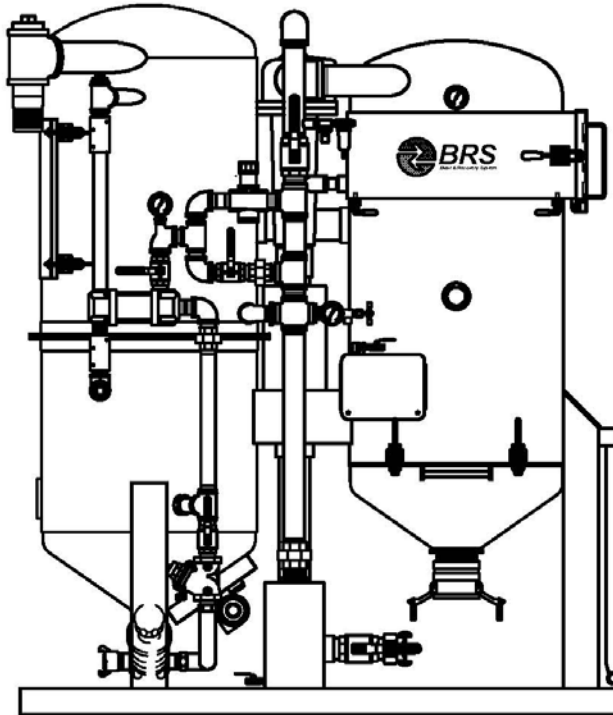

## OWNER'S MANUAL

JULY 1998

Rev.4/10



# SCHMIDT

SAVE THIS MANUAL AND MAKE AVAILABLE  
TO ALL USERS OF THIS EQUIPMENT!

Manual Part Number 7200-220



AXXIOM Manufacturing, Inc.  
11927 S. Highway 6, Fresno, Texas 77545  
800.231.2085 \* 281.431.0581 \* fax 281.431.1717



# WARNING

- 1. Any person intending to operate this equipment or any person intending to be in the vicinity during its operation that cannot read or completely understand all of the warnings, operating procedures and instructions, and the rules for safer operation contained in this manual must receive proper training from their supervisor and/or employer. Consult Axxiom Manufacturing, Inc.**
- 2. Do not operate any abrasive blaster or blast equipment before reading and completely understanding all the warnings, operating procedures and instructions, and the rules for safer operation contained in this manual.**
- 3. Do not operate any abrasive blaster or blast equipment without following the rules for safer operation and all the operating procedures and instructions. Failure to properly use blast equipment could result in serious injury or death.**
- 4. Do not perform any maintenance while any abrasive blaster or blast equipment is pressurized. Always depressurize any vessel before loading media or performing any maintenance.**
- 5. Do not use abrasives containing free silica. Silica can cause silicosis or other related respiratory damage. You must wear personal protective equipment for all abrasive blasting operations. Observe all applicable local, state and federal safety regulations in conjunction with airline filters and respiratory protection. Reference OSHA (Occupational Safety and Health Administration).**
- 6. Do not enter areas during abrasive blasting operations without breathing protection. All personnel in the vicinity of abrasive blasting operations should wear NIOSH approved air fed respirators, hoods or helmets.**
- 7. Do not modify or alter any abrasive blaster, blast equipment or controls thereof without written consent from Axxiom Manufacturing, Inc.**
- 8. Do not use bleeder type deadman valves on any Schmidt® abrasive blasters. The use of A-BEC, Clemco or a similar bleeder type deadman valve can cause unintentional start-up without warning, which can result in serious personal injury.**
- 9. Do not sell, rent, or operate abrasive blasters without remote controls. OSHA regulations require remote controls on all blast machines. Failure to use remote controls can cause serious injury or death to the operator(s) or other personnel in the blasting area. (Reference OSHA regulations.)**
- 10. Do not repair or replace any portion of Schmidt equipment using components that are not Schmidt original replacement parts. Use of replacement components that are not Schmidt original replacement parts may result in equipment failure which can result in serious personal injury and will void all warranties.**

## **0.0 SAFETY WARNINGS**

### **0.1 Important Safety Instructions**

- 0.1.1 Do not remove, repair or replace any item on vessel while it is under pressure.
- 0.1.2 Do not operate if there is a leak in the vessel. Immediately take vessel out of service and call your certifying authority.
- 0.1.3 Do not operate above maximum allowable working pressure (MAWP) at maximum operating temperature (°F) shown on ASME nameplate.
- 0.1.4 Do not weld, grind or sand vessel. It will not be safe to operate.
- 0.1.5 Do not operate if the vessel has been damaged by fire. Take out of service immediately and notify your certifying authority.
- 0.1.6 Any damage to vessel can make it unsafe. Inspect outside and inside of vessel regularly for corrosion or damage (i.e. dents, gouges or bulges). If damaged take out of service immediately and notify your certifying authority.
- 0.1.7 Do not connect the air discharge on this unit onto a common header with any other unit of any description, or any other source of compressed air, without first making sure a check valve is used between the header and this unit. If this unit is connected in parallel with another unit of higher discharge pressure and capacity, a safety hazard could occur in a back-flow condition.

### **0.2 Recommended Safe Procedures**

- 0.2.1 Never attempt to perform maintenance while the unit is under pressure or is even capable of being pressurized. This means at a minimum the inlet ball valve should be closed and ideally the air source be shut off or disconnected. Anytime the manual blow-down valve is closed it should be assumed that the unit is under pressure.
- 0.2.2 This machine contains high pressure air which can cause severe injury or death from flying parts. Always relieve pressure before removing covers, plugs, caps or other parts from the pressurized air system. Follow these rules for safe operation.
  - Do not remove access cover until all air pressure is out of vessel.
  - Do not try to tighten cover if you hear or feel a leak. Immediately shut off air supply to vessel and reduce pressure to zero. Install a new cover and gasket.
  - Do not use power tools or cheater bars to tighten nut on cover. Too much force can distort cover and/or gasket. If damaged by over tightening, the cover can blow out and cause serious injury.
  - Inspect cover and sealing surface every time cover is removed or at least once a year for damage such as corrosion, cracks or distortion. If there is any damage, install a new cover and/or gasket.
- 0.2.3 Wear suitable eye protection when filling the unit. There is a possibility that some abrasive may be blown back as the pop-up valve seats.
- 0.2.4 Always keep hands well clear of the working area of the pop-up valve.
- 0.2.5 Periodically check all hoses to see that they are in good condition. Repair any valves or hoses that show any signs of wear or leakage.
- 0.2.6 All blast hose couplings and air hose couplings are provided with holes which must be safety pinned or wired to prevent accidental disconnections.
- 0.2.7 The interior condition of the vessel should be inspected regularly for corrosion.
- 0.2.8 All blast equipment operators must use respiratory protective equipment approved by the Bureau of Mines and NIOSH so that they will meet OSHA regulations.
- 0.2.9 All blast systems must be equipped with automatic (deadman) type remote controls. (See OSHA specifications 29CFR1910.244(b).)

# **TABLE OF CONTENTS**

**0.0 SAFETY WARNINGS**

**1.0 GENERAL DATA**

**2.0 THEORY OF OPERATION**

**3.0 OPERATING PROCEDURES**

**4.0 MAINTENANCE**

**5.0 PARTS LIST**

**6.0 BLASTING DATA**

**7.0 TROUBLE SHOOTING**

## 1.0 GENERAL DATA

### 1.1 Blast & Recovery System (BRS) Dimensional Specifications

MODEL No.	PART No.	HEIGHT in (cm)				WIDTH in (cm)		LENGTH in (cm)	WEIGHT lbs (kg)			
		skid mount		portable		skid mount	portable		skid mount		portable	
		cyclone	air wash	cyclone	air wash				cyclone	air wash	cyclone	air wash
BRS 2.0	8031-020	72 (183)	74 (189)	76 (194)	78 (199)	27 (69)	35 (89)	59 (150)	500 (227)	650 (295)	600 (295)	750 (340)
BRS 3.5	8031-030	81 (206)	86 (219)	88 (224)	93 (237)	36 (91)	53 (135)	68 (173)	1410 (535)	1510 (685)	1560 (603)	1660 (753)
BRS 6.5	8031-060	100 (254)	109 (277)	107 (272)	116 (295)	36 (91)	53 (135)	68 (173)	1510 (685)	1610 (730)	1660 (753)	1760 (798)

MODEL No.	VESSEL VOLUME cu. ft. (Liters)	MEDIA RECLAIMER VOLUME cu. ft. (liters)	
		standard cyclone	adjustable air wash
BRS 2.0	2.0 (57)	2.4 (68)	2.0 (57)
BRS 3.5	3.5 (100)	6.6 (187)	3.5 (100)
BRS 6.5	6.5 (184)	8.3 (235)	6.5 (184)

### 1.2 Blast & Recovery System (BRS) Operational Specifications

Maximum Working Pressure	125 psi @ 250°F
Minimum Metal Temperature	-20°F @ 125 psi
Blast Hose Size	Up to 1 1/2" (see section 6.0 table 3)
Air Consumption	See section 6.0 table 1
Abrasive Consumption	See section 6.0 table 2

**\*Note:** 150 psi maximum working pressure is optional. Check vessel nameplate.

### 1.3 Warranty

All Schmidt products are guaranteed to be free of defects in material and workmanship at time of shipment. Schmidt will replace any of its products or component parts thereof which thus prove defective under proper use within three months of the date sold, provided that prompt notice has been given to Schmidt. However, Schmidt's liability is limited to replacement of such defective products or components and Schmidt shall have no liability for labor, consequential damages, freight or special charges. Use of replacement parts that are not original Schmidt factory replacement parts furnished by an authorized Schmidt / Axxiom distributor will void all warranties. This warranty is in lieu of all other representations.

#### Return Merchandise Policy

In no case is merchandise to be returned to Schmidt for credit without authorization. At the time of authorization, Schmidt will issue a return authorization number which must be included on all packages and correspondence. Any material returned without prior authorization will remain authorization will remain the property of the sender and Schmidt will not be responsible for same.

All returns must be shipped prepaid freight. All returns may be exchanged for other equipment or parts of equal dollar value. If goods are not exchanged, they are subject to a 15% restocking charge. Any cost incurred by Schmidt to restore such goods to first class condition will be charged to the customer.

## **2.0 THEORY OF OPERATION**

The function of the BRS unit is to blast and recover abrasive media. The BRS is designed to blast, vacuum, or blast and vacuum simultaneously. The media is contained in the pressure vessel for blasting. After blasting, media is recovered in the media reclaimer by means of a pneumatic vacuum system. Small particles are carried by the vacuum air stream into the dust collector. The media and large particles (paint chips, cigarette butts, etc) drop to the bottom of the media reclaimer. The media is reloaded at atmospheric condition from the media reclaimer into the pressure vessel after passing through a screen.

This manual contains part identification numbers (#) within the text that are found on the drawings in section 5.0, page #5-3 thru #5-15. Refer to these drawings as needed while reading this manual.

### **2.1 AIR SUPPLY**

Compressed air is supplied through a hose connection and passes through the inlet ball valve (#1). Then it goes through the moisture separator (#2). The moisture separator has a ball valve (#3) located at the bottom to drain the moisture collected. During operation this ball valve (#3) should be slightly open so that the moisture collected can drain. After passing through the moisture separator the air supply branches into various locations. The first location is the air supply for the pulse jet system. The second location is the air supply for the media vibrator (optional). The third location is the vessel pressurization piping which includes the combo valve and the blast air line. The last location is the air supply for the vacuum system.

### **2.2 VESSEL PRESSURIZATION PIPING**

#### **2.2.1 Combo Valve**

The vessel pressurization is controlled by the combo valve (#5). The combo valve is dual function valve that is essential in the blowdown and blasting operations. On one end, it is a valve that pinches a 3/4" blowdown hose (#6) to close the vessel and allow pressurization, and releases the hose to depressurize the vessel. The air released during depressurization escapes into the media reclaimer through the blowdown hose (#6). Note that there is an orifice (#55) installed in the blowdown line which prevents the blowdown air from overpowering the vacuum in the media reclaimer. The other end of the combo valve is a on-off type valve for the air supply to pressurize the vessel and for blasting. The two functions operate simultaneously when the deadman lever (#13) is depressed, allowing remote vessel pressurization/blast initiation and vessel depressurization/blast termination. The minimum pressure to open the combo valve is 55 psig.

#### **2.2.2 Regulated Bypass Piping**

An optional feature of the BRS is the regulated bypass piping whose function is to allow blasting at lower pressures. To activate the regulated bypass controls simply close ball valve (#9), then the vessel/blast pressure can be adjusted by the pressure regulator (#10) located upstream of the combo valve. Turn the knob clockwise to increase the pressure and counter-clockwise to reduce the pressure. To resume full pressure blasting open the ball valve (#9).

## **2.3 BLAST AIR LINE**

### **2.3.1 Choke Valve**

The choke valve (#11) is a ball valve located in blast air line upstream of the automatic air valve and Thompson Valve. The function of the choke valve is to aid in the removal of any obstruction that may, despite all effort, find its way into the blast pot. Whenever a large particle (paint chip, cigarette butt, etc.) obstructs the Thompson Valve the procedure is to open the Thompson Valve to the fully open position and then close the choke valve completely for about one second while the deadman lever (#13) is depressed. If the BRS is equipped with the abrasive cut-off feature set the switch (#14) to the on-position for the choke procedure. This should be sufficient to dislodge whatever foreign material that may have obstructed media flow through the Thompson Valve. The choke valve should be left in the full open position on all other occasions.

### **2.3.2 Automatic Air Valve**

The automatic air valve (#58) is a normally closed pneumatically operated air valve. The normal function of the air valve is the supply of blast air when the deadman lever (#13) is depressed. However, in the BRS system the automatic air valve (#58) prevents the air in the blast pot from exhausting through the pop-up piping (#24) and out of the blast hose during vessel blowdown. This reverse flow is a condition caused by the implementation of the blowdown orifice (#55). Refer to section 2.2.1.

### **2.3.3 Thompson Valve**

The Thompson Valve (#12) is a dual function valve. First, it is an abrasive metering valve. Second, it is an on-off valve that blocks or releases abrasive media into the blast air stream. When it is open the Thompson valve meters through a adjustable orifice. The degree to which this orifice is open is determined by the turning the knob at the top of the Thompson valve (CW-close, CCW-open). The Thompson valve is controlled by the deadman valve (#13) via control valve(s) (#16 and/or #15). Note that if the BRS unit is equipped with the abrasive cut-off feature (#14), the switch must be set to the on-position for the Thompson valve to open otherwise only blast air will exit out of the nozzle.

### **2.3.4 Abrasive Cut-off**

An optional feature of the BRS is the abrasive cut-off. The function of the abrasive cut-off is to allow blasting air without media. To blast with air only set the abrasive cut-off switch (#14) to the off-position then depress the deadman lever (#13). This will send a control signal to the combo valve and automatic air valve only. As a result only blast air will exit out of the nozzle. The abrasive cut-off feature necessitates the addition of a control valve (#16) which provides the control signal to the Thompson valve independent to that of the combo valve and air valve.

## **2.4 VACUUM SYSTEM**

### **2.4.1 Pneumatic Vacuum Pump (Eductor)**

The vacuum system is used for media recovery during closed blasting (simultaneous blasting and recovery), or when solely vacuuming media. The principal component of the vacuum system is the pneumatic vacuum pump (#18). The vacuum pump is powered by a minimum of 150 CFM of compressed air at 100 psig. To activate the vacuum system open the ball valve (#17) located in the air supply piping. The vacuum generated by the vacuum pump can be regulated by the supply ball valve (#17). When closed blasting it may be necessary to reduce the vacuum to prevent warpage of thin materials. To reduce the level of vacuum, slightly close the ball valve

(#17) to obtain the desired vacuum. The vacuum pressure is indicated on the pressure gauge (#34) located on the dust collector (#26). The vacuum pump exhausts air through a muffler (#20) and into the BRS frame which further muffles the exhaust and diffuses the air velocity. For varying vacuum applications the pneumatic vacuum pump (#18) can be equipped with a 150, 225, 350, or 440 CFM nozzle (#19) (Refer to section 3.3.2 for procedure to determine the nozzle size).

#### **2.4.2 Cyclone Media Reclaimer**

The function of the media reclaimer (#21) is to receive the media recovered by vacuuming. The media and other debris enter the media reclaimer at the tangential inlet (#53) which creates a cyclonic action on the incoming flow (refer to drawing on page #5-7). Large heavier particles spiral on the outer extreme and are carried to the bottom of the media reclaimer. Small lighter particles remain in the air stream and are carried from the media reclaimer into the dust collector (#26). At the bottom of the media reclaimer there is a screen (#22) that prevents debris (paint chips, cigarette butts, etc.) from passing into the pressure vessel (#23). When blasting is interrupted, the pressure vessel pop-up valve (#24) opens which allows the media accumulated in the media reclaimer to fall through the screen and enter the pressure vessel. The screen should be inspected and cleaned periodically. It can be accessed through the access door (#44) of the media reclaimer.

#### **2.4.3 Adjustable Air Wash Media Reclaimer**

An optional feature of the BRS is the media reclaimer with the adjustable air wash system (refer to drawing on page #5-7). The air wash reclaimer is a two stage media separator. The first stage operates as described above for the cyclone media reclaimer where the primary media separation occurs at the bottom of the upper cylinder (a). The remaining debris and media falls downward through the conical orifice (b). At this point smaller particles are washed from the media by the vacuum flow into the cone tube (c) and flows into the dust collector through the reclaimer outlet (d). The vacuum intensity at the cone tube is adjusted by the urethane cone tube plug (e). The adjustment is made by loosening the collar screw (f) and raising or lowering the urethane cone tube plug. Raising the urethane plug increases the air wash vacuum intensity, while lowering it decreases the intensity. This adjustment is necessary to optimize dust removal while also minimizing removal of good media. At the bottom of the media reclaimer there is a screen (#22) mounted on vibration isolators (#66) that prevents debris (paint chips, cigarette butts, etc.) from passing into the pressure vessel (#23). Located on the screen is a media vibrator (#61) to aid in media flow through the screen. The screen should be inspected and cleaned periodically. It can be accessed through the access door (#44) of the media reclaimer.

#### **2.4.4 Dust collector**

The dust-filled vacuum air stream from the media reclaimer enters the dust collector (#26) where the dust particles are filtered out by one of three available methods (wet filtration, dry filtration or HEPA filtration). The clean vacuum air stream is evacuated from the dust collector through the vacuum pump (#18).

##### **2.4.4.1 Wet filtration**

The first viable method of filtration by the dust collector (#26) is wet filtration. This method pulls the dust-filled air stream through water which traps the dust particles. After rising through the water, the air stream passes through a stainless steel demister filter (#27) to remove any water droplets that may have mixed with the air stream. The demister

filter is a removable component that fits in the box section of the dust collector through the latched door (#45). After sliding the demister filter (#27) into the box section, close and latch the door, then push it into position with the four retractable locators (#29). The dust collector is filled with water through a 2" connection (#31) up to the bottom of the connection. The water in the dust collector should be changed periodically. The ideal time to do so is at the end of the work day before the dust has settled to the bottom. The water can be drained through the ball valve (#46) at the bottom of the dust collector. The dry filter and HEPA filter (if so equipped) must be removed from the dust collector prior to operating with wet filtration.

#### **2.4.4.2 Dry filtration**

The second optional method of filtration is dry filtration. This method utilizes a pleated filter that fits in the round section of the dust collector. The dry filter [10" (#62), 12" (#32) or 18" (#33)] is installed through the latched bottom head (#52) of the dust collector. The filter is held in position by the wingnut (#56) which seals it against the bottom of the box section of the dust collector. The dry filter must be pulsed regularly during operation to prevent clogging (see section 2.5). In addition the filter must be periodically cleaned to insure long life (see section 4.4.3).

#### **2.4.4.3 HEPA filtration**

When particulate free exhaust air is required, the optional HEPA (High Efficiency Particulate Air) filter (#28) can be installed. The HEPA filter is tested by DOP method to be 99.97% efficient on particles 0.3 microns in size or larger. In this arrangement the air passes through the dry filter (#32, #33 or #62), then passes through the HEPA filter before exhausting. The HEPA filter fits in the box section of the dust collector through the latched door (#45). After sliding the HEPA filter into the box section, close and latch the door, then push it into position with the four retractable locators (#29). This seals the filter against the bottom of the box section of the dust collector. The dry filter (#32, #33 or #62) must be used in conjunction with the HEPA filter.

## **2.5 PULSE JET SYSTEM**

The function of the pulse jet system is to prevent clogging of the dry filter (#32, #33 or #62) by periodically providing a burst of air inside the filter to loosen dust particles from the pleated surface. This is accomplished manually or by the optional automatic pulse jet controls. The required interval between pulses is determined by the blasting conditions. As the particles begin to clog the filter the vacuum pressure within the dust collector will increase. This increase can be detected on the pressure gauge (#34). The pulsing air supply utilizes a reservoir (#67) to prevent pressure drops at the blast nozzle. The reservoir has a ball valve (#68) located at the bottom to drain the moisture collected. During operation this ball valve (#68) should be slightly open so that the moisture collected can drain.

### **2.5.1 Manual Pulse**

The manual pulse process is totally operator dependant and requires consistent operation to insure trouble free vacuum filtration. The manual pulse requires the operator to periodically open the ball valve (#40) for a fraction of a second which provides the burst of air to loosen entrapped particles. The pulse should be actuated regularly during closed blasting (blasting w/vacuum recovery) and may require a second operator.

### **2.5.2 Automatic pulse jet controls**

The automatic pulse system provides operator-free pulsing of the dry filter and operates only when the vacuum pump (#19) is powered. The automatic pulse jet is controlled by a pneumatic oscillator (#59) located in the pulse air control box (#35) (refer to drawing in section 5.0, page #5-8). Upstream of the pulse air control box an air filter (#38) and a non-adjustable regulator (#39) are installed to maintain the clean air, of a maximum of 80 psig, required by the pulse controls. The pulse air control box sends a signal to an automatic air valve (#36), via a control valve (#60), which opens providing the burst of air necessary to unclog the dry filter (#32, #33 or #62). The adjustment of the pulse air control box is dictated by the blasting conditions. The interval between pulses is adjusted by the upper knob (T1) on the oscillator (#59). The pulse length is adjusted by the lower knob (T2). The pulse effect can be seen by a decrease in the vacuum reading on the pressure gauge (#34). The automatic pulse jet controls can be disabled by closing the ball valve (#37). In addition, manual pulsing can be applied by opening the three-way ball valve (#69) which sends an air signal to the automatic air valve (#36). The purpose of this feature is to allow pulsing to clean the dry filter without the operation of the vacuum pump.

## **2.6 MEDIA VIBRATOR (vessel)**

The media vibrator (#41) is an optional feature whose function is to vibrate the media in the pressure vessel (#23) which creates better media flow characteristics. The level of vibration is controlled by the angle valve (#42) which can also turn off the vibration.

## **2.7 MEDIA VIBRATOR (media screen)**

The air wash media reclaimer is equipped with a screen mounted vibrator to increase flow through the screen (refer to drawing on page #5-7). The level of vibration is controlled by the angle valve (#63) which can also turn off the vibration. The vibrator can be accessed by removing the screen through the access door (#44).

## **2.8 BLAST HOSE ASSEMBLY**

The size of the blast hose is determined by the size nozzle to be used. Generally the blast hose inside diameter should be three times the nozzle throat diameter. For open cycle blasting (without vacuum recovery) conditions and preference dictate the size nozzle/hose combination to be used. However, to utilize closed cycle blasting which requires the BRS vacuum head, only a 3/4" blast hose assembly can be used. This is due to the limitations inherent to this type of blasting which require size constraints designed into the BRS vacuum head. The use of a 3/4" blast hose implies that the largest size nozzle that can be used during closed cycle blasting is a #4 (1/4"), but a #5 (5/16") can also be used effectively.

## **2.9 BLAST NOZZLE**

While blasting, the blast air/media mixture flows through the blast hose (#54) to the blast nozzle (# 51). The blast nozzle throat diameter directly affects the air flow rate, media flow rate, and

surface removal rate. Nozzles come in several sizes which can be identified by a small number visible on the nozzle. This number represents the nozzle throat diameter size in sixteenths of an inch; for example, a #5 nozzle has a throat diameter of 5/16". The best nozzle size for a particular application can be determined by several factors:

- i. How much compressed air is available? Refer to section 6.0, table 1 for the approximate air consumption for each size blast nozzle
- ii. Will blasting be done open cycle (w/o vacuum recovery) or closed cycle (w/simultaneous vacuum recovery)? When closed blasting, the blast air flow must not be greater than the vacuum pump (#18) capacity. This will prevent blast air and dust from blowing out around the nozzle brushes on the BRS vacuum head (#50). The recommended blast nozzle size to be used in closed blasting varies depending on the length and diameter of the vacuum hose. Use the following general guidelines for reference:

BLAST PRESSURE	NOZZLE SIZE
15 psi or less	#7 Nozzle
30 psi or less	#6 Nozzle
50 psi or less	#5 Nozzle
100 psi or less	#4 Nozzle

Open blasting (w/o vacuum recovery) can be done with any size nozzle, but for higher production a #8 (1/2") nozzle is most commonly used.

- iii. What type of surface is being blasted? Blasting small or intricate parts is usually done with a smaller nozzle.

## **2.10 BRS VACUUM HEAD**

The vacuum head (#50 or #64) is used when operating in the closed blasting mode (blasting with simultaneous vacuum recovery). The blast media is contained within the vacuum head where from it is recovered by the vacuum system. The blast nozzle (#51) screws into the nozzle holder (#54) of the blast hose assembly, which in turn fits into the BRS vacuum head (#50 or #64). Then the suction hose attaches to the side of the vacuum head. The vacuum hose to BRS head is usually a tight fit, so no further seal is required at that joint. All other joints in the vacuum line are sealed with hose clamps. There are two style vacuum heads that are used with the BRS (refer to the drawings on page #5-15), each is equipped with brushes and a center wear tube that attach to the working end of the head. The brushes and center tube are wear components and should be inspected and replaced periodically. When operating in the closed blasting mode requiring the use of a vacuum head assembly, it is important to remember that this limits the size of blast nozzle (#51) that can be used due to limitations created by the blast head and the available compressed air volume. Refer to section 3.3 to determine compressed air requirements.

### **3.0 OPERATING PROCEDURE**

This section contains part identification numbers (#) within the text that are found on the drawings in section 5.0, pages #5-3 thru #5-15. Refer to these drawings as needed while reading this manual. Prior to operating the BRS unit, carefully read the safety warnings in section 0.0.

#### **3.1 OPEN CYCLE BLASTING (blasting without vacuum recovery)**

##### **3.1.1 Unit Set Up:**

- 3.1.1.1 To prevent static electricity shocks to operating personnel, the BRS unit must be grounded.
- 3.1.1.2 Close the air inlet ball valve (#1), the pneumatic vacuum pump ball valve (#17), the vessel pressurization ball valve (#7), the media vibrator valve (#42 if so equipped), media screen vibrator valve (#63 if so equipped) and the pulse jet ball valve(s) (#37 & #69, or #40).
- 3.1.1.3 Make sure the handway (#43) on the blast pot (#23) is closed and tightened.
- 3.1.1.4 Remove BRS vacuum head (#50 or #64) from blast hose assembly.
- 3.1.1.5 Screw a standard long venturi nozzle (#51) into the nozzle holder (#54) of the blast hose assembly.
- 3.1.1.6 Connect the blast hose (#54) to the coupling on the Thompson valve (#12) and install safety clips to prevent accidental disconnection during operation.
- 3.1.1.7 Connect the twinline hose quick connects (#57) to the mating quick connects on the control valve(s) (#16 and/or #15).
- 3.1.1.8 Connect the vacuum hose assembly to the vacuum inlet (#53).
- 3.1.1.9 Connect an air supply hose to the air inlet crowfoot on the BRS and install safety clips to prevent accidental disconnection during operation. Refer to section 3.3 to determine the compressed air requirements. Note that the pneumatic vacuum pump consumes air in addition to the air requirements of the blast nozzle. The amount of air consumed by the pump depends on the vacuum pump nozzle size (150, 225, 350 or 440 CFM). Refer to section 3.3.2 to determine the nozzle size.
- 3.1.1.10 If the blast pot is already full of media skip to section 3.1.2. To fill the blast pot disconnect the vacuum hose from the BRS vacuum head (#50 or #64).
- 3.1.1.11 Make sure the handway and doors (#43, #44, #45 & #52) on blast pot (#23), media reclaimer (#21) and dust collector (#26) are closed tight.
- 3.1.1.12 Open the air inlet valve (#1).
- 3.1.1.13 Open valve (#17) to turn on vacuum pump (#19).

3.1.1.14 Vacuum desired amount of media into the blast pot (#23). Do not overfill, for this will cause media overflow into the dust collector when blasting with vacuum recovery (refer to section 1.1 for capacity). If the media being used is low density, it may be necessary to reduce the vacuum to prevent carryover of new media into the dust collector. The vacuum generated by the vacuum pump (#18) can be regulated by the supply ball valve (#17). To reduce the level of vacuum, slightly close the ball valve (#17). Note: If the unit is equipped with an adjustable air wash media reclaimer, the vacuum intensity at the cone tube (c) may also require adjustment. Refer to section 2.4.3.

3.1.1.15 Close valve (#17) to turn off vacuum pump (#19).

### **3.1.2 Open Cycle Blasting Operation:**

3.1.2.1 After completion of the procedures in section 3.1.1, the BRS unit is now ready for open cycle blasting (blasting without simultaneous vacuum recovery).

3.1.2.2 Open the air inlet ball valve (#1).

3.1.2.3 Set your desired tank/blast pressure (if so equipped) by turning the pressure regulator (#10) knob clockwise for higher pressure or counterclockwise for lower pressure. Remember that when blasting, the pressure indicated on the pressure gauge (#8) will drop slightly.

3.1.2.4 To operate at full pressure, without the regulator restriction, open ball valve (#9).

3.1.2.5 Partially open the drain ball valves (#3 & #68) at the bottom of the moisture separator (#2) and reservoir (#67) to allow accumulated moisture to drain. This prevents moisture from entering the blast pot (#23) and dust collector (#26) during blasting.

3.1.2.6 Open the Thompson Valve (#12) slightly. The best setting for this valve differs from one situation to another; therefore, it may take more than one adjustment to achieve the desired air/media mixture. Turn the Thompson Valve knob clockwise to decrease media flow or counterclockwise to increase media flow.

3.1.2.7 Turn on vessel media vibrator (#41 if so equipped) and set to the desired level of vibration by adjusting the angle valve (#42).

3.1.2.8 If the unit is equipped with an adjustable air wash media reclaimer, turn on media screen vibrator (#61) and set to the desired level of vibration by adjusting the angle valve (#63).

3.1.2.9 Open the choke valve (#11) and vessel pressurization ball valve (#7).

3.1.2.10 Depress the pneumatic deadman lever (#13) to begin blasting. Note that if the BRS is equipped with the abrasive cut-off feature, switch (#14) must be set to the "on" position to blast with media.

## 3.2 CLOSED CYCLE BLASTING (blasting with vacuum recovery)

This section contains part identification numbers (#) within the text that are found on the drawings in section 5.0, pages #5-3 thru #5-15. Refer to these drawings as needed while reading this manual. Prior to operating the BRS unit, carefully read the safety warnings in section 0.0.

### 3.2.1 Unit Set Up:

#### *Wet Filtration*

- 3.2.1.1 To prevent static electricity shocks to operating personnel, the unit must be grounded.
- 3.2.1.2 Open valve (#46) to drain water mixed with spent media out of dust collector (#26).
- 3.2.1.3 Close valve (#46).
- 3.2.1.4 Be sure there are no dry filters (#28, #32, #33 or #62) installed in the dust collector. Then remove water fill dust cap (#31) on dust collector and fill with water until the level reaches the bottom of the coupling.
- 3.2.1.5 Reinstall water fill dust cap (#31).
- 3.2.1.6 Open the latched door (#45) of the box section of the dust collector. Install the stainless steel demister filter (#27). Close and latch the door (#45) then raise the demister into position with the four retractable locators (#29). Skip to step 3.2.1.12 .

#### *Dry Filtration*

- 3.2.1.7 To prevent static electricity shocks to operating personnel, the unit must be grounded.
- 3.2.1.8 Remove drain dust cap (#48) at the bottom of the dust collector (#26) to drain the spent media.
- 3.2.1.9 Reinstall the drain dust cap (#48).
- 3.2.1.10 Open the hinged head (#52) of the dust collector. Install the dry filter [10" (#62), 12" (#32) or 18" (#33)] in the round section of the dust collector (#26) and secure in position with the wingnut. Close and latch the hinged head (#52).
- 3.2.1.11 Open the latched door (#45) on the box section of the dust collector. Install the HEPA filter (#28 if so equipped). Close and latch the door (#45) then raise the filter into position with the four retractable locators (#29).
- 3.2.1.12 Close the air inlet ball valve (#1), the pneumatic vacuum pump ball valve (#17), the vessel pressurization ball valve (#7), the vessel media vibrator valve (#42 if so equipped), media screen vibrator valve (#63 if so equipped) and pulse jet ball valve(s) (#37 & #69, or #40).

- 3.2.1.13 Make sure the handway (#43) on the blast pot (#23) is closed and tightened.
- 3.2.1.14 Screw a standard long venturi nozzle (#51) into the nozzle holder (#54) of the blast hose assembly.
- 3.2.1.15 Connect the BRS vacuum head (#50 or #64) to the nozzle holder (#54) of the blast hose assembly. Refer to drawing on page #5-15.
- 3.2.1.16 Connect the blast hose (#54) to the coupling on the Thompson valve (#12) and install safety clips to prevent accidental disconnection during operation.
- 3.2.1.17 Connect the twinline hose quick connects (#57) to the mating quick connects on the control valve(s) (#16 and/or #15).
- 3.2.1.18 Connect the vacuum hose assembly to the vacuum inlet (#53).
- 3.2.1.19 Connect an air supply hose to the air inlet crowfoot on the BRS and install safety clips to prevent accidental disconnection during operation. Refer to section 3.3 to determine the compressed air requirements. Note that the pneumatic vacuum pump consumes air in addition to the air requirements of the blast nozzle. The amount of air consumed by the pump depends on the vacuum pump nozzle size (150, 225, 350 or 440 CFM). Refer to section 3.3.2 to determine the nozzle size.
- 3.2.1.20 If the blast pot is already full of media, skip to section 3.2.2. To fill the blast pot disconnect the vacuum hose from the vacuum head (#50 or #64).
- 3.2.1.21 Make sure the handway and doors (#43, #44, #45 & #52) on blast pot (#23), media reclaimer (#21) and dust collector (#26) are closed tight.
- 3.2.1.22 Open the air inlet valve (#1).
- 3.2.1.23 Open valve (#17) to turn on vacuum pump (#19).
- 3.2.1.24 Vacuum desired amount of media into the blast pot (#23). Do not overfill, for this will cause media overflow into the dust collector while blasting with vacuum recovery (refer to section 1.1 for capacity). If the media being used is low density, it may be necessary to reduce the vacuum to prevent carryover of new media into the dust collector. The vacuum generated by the vacuum pump (#18) can be regulated by the supply ball valve (#17). To reduce the level of the vacuum, slightly close the ball valve (#17). Note: If the unit is equipped with an adjustable air wash media reclaimer, the vacuum intensity at the cone tube (c) may also require adjustment. Refer to section 2.4.3.
- 3.2.1.25 Close valve (#17) to turn off vacuum pump (#19).
- 3.2.1.26 Re-attach vacuum hose to the BRS vacuum head (#50 or #64)).

### **3.2.2 Closed Cycle Blasting Operation**

- 3.2.2.1 After completion of the procedures in section 3.2.1, the BRS unit is now ready for closed cycle blasting (blasting with simultaneous vacuum recovery).
- 3.2.2.2 Open air inlet ball valve (#1).
- 3.2.2.3 Set your desired tank/blast pressure (if so equipped) by turning the pressure regulator (#10) knob clockwise for higher pressure or counterclockwise for lower pressure. Remember that when blasting, the pressure indicated on the pressure gauge (#8) will drop slightly.
- 3.2.2.4 To operate at full pressure, without the regulator restriction, open ball valve (#9).
- 3.2.2.5 Partially open the drain ball valves (#3 & #68) at the bottom of the moisture separator (#2) and reservoir (#67) to allow accumulated moisture to drain. This prevents moisture from entering the blast pot (#23) and dust collector (#26) during blasting.
- 3.2.2.6 Open the Thompson Valve (#12) slightly. The best setting for this valve differs from one situation to another; therefore, it may take more than one adjustment to achieve the desired air/media mixture. Turn the Thompson Valve knob clockwise to decrease media flow or counterclockwise to increase media flow.
- 3.2.2.7 Open valve (#17) to turn on vacuum pump.
- 3.2.2.8 Before blasting, inspect the brushes on the BRS vacuum head (#50) and replace any that are worn or damaged.
- 3.2.2.9 Place the BRS vacuum head (#50) against the surface to be blasted until the brushes seal against the blasting surface. The vacuum gauge (#34) on the dust collector (#26) should read about  $\frac{1}{2}$  to 4" Hg.
- 3.2.2.10 Turn on media vibrator (#41 if so equipped) and set to the desired level of vibration by adjusting the angle valve (#42).
- 3.2.2.11 If the unit is equipped with an adjustable air wash media reclaimer, turn on media screen vibrator (#61) and set to the desired level of vibration by adjusting the angle valve (#63).
- 3.2.2.12 Open the choke valve (#11) and vessel pressurization ball valve (#7).
- 3.2.2.13 Set the automatic pulse (if so equipped) to the desired level (refer to section 2.5). The optimum setting varies depending on blast conditions therefore more than one adjustment may be needed.
- 3.2.2.14 Depress the pneumatic deadman lever (#13) to begin blasting. Note that if the BRS is equipped with the abrasive cut-off feature, switch (#14) must be set to the "on" position to blast with media.

### 3.3 COMPRESSED AIR REQUIREMENTS

#### 3.3.1 Blast nozzle

One of the primary air expenditures is by the blast nozzle. This expenditure can vary greatly depending upon the nozzle size and the blast pressure. See section 6.0 table 1 for air consumption by nozzle size at various pressures.

#### 3.3.2 Pneumatic vacuum pump nozzle

The BRS unit uses a pneumatic vacuum pump in its recovery system. The amount of air consumed by the pneumatic vacuum pump is determined by the vacuum pump nozzle size. The pneumatic vacuum pump nozzle can be one of four different sizes (150, 225, 350, or 440 CFM). At the time of manufacturing, a decal is placed on the exhaust muffler (#20) that identifies the size of the vacuum pump nozzle. If the decal is not present on the unit, the vacuum pump nozzle size can be found stamped on the flange of the nozzle (#19). The nozzle can be removed through the pipe tee located at the pump air inlet (#18) by first removing the pipe plug from the tee.

**Note:** On units manufactured prior to June 1998, the vacuum pump nozzle (#19) can be accessed by loosening the 2" pipe union located near the air inlet of the vacuum pump (#18). After loosening the union, remove the 2" elbow with pipe nipple to view or remove the vacuum pump nozzle.

#### 3.3.3 Air compressor size

The air compressor must be large enough to supply:

- i. Blast air for the largest nozzle and the highest pressure that will be used (see section 6.0 table 1).
- ii. The air requirement dictated by the pneumatic vacuum pump nozzle size.
- iii. The 12 CFM breathing air supplied to the blast hood when open blasting.

Since the pneumatic vacuum pump consumes a minimum of 150 CFM at 100 psig, the air supply hose from the air compressor to the BRS unit should be at least 1 1/2" in diameter. This size hose will supply the necessary air flow to simultaneously operate the vacuum pump and blast nozzle.

## **4.0 NORMAL MAINTENANCE**

This section covers maintenance that should be performed at regular intervals to insure proper operation of the BRS unit. All the procedures discussed in this section should be performed with the BRS unit completely depressurized and the air supply hose disconnected. Refer to the drawings in section 5.0 to aid in the completion of any maintenance.

### **4.1 Combo valve**

The black hose (#6) that passes through the combo valve (#5) is a 3/4" blast hose. Media carry-over can abrade a hole through the wall of the hose. Simply replace the hose with another section of hose, but make sure that the hose does not make any tight bends anywhere between the blast pot and the cyclone because this will cause the wear to be much more rapid. Periodically check the blowdown orifice (#55) for wear. Excessive wear of the orifice can allow the blowdown air to overpower the cyclone vacuum.

### **4.2 Thompson valve**

If a blast nozzle will not shut off completely, it is probably because of a worn Thompson valve seat. It is replaced by unbolting the base of the valve (when the BRS unit is depressurized).

### **4.3 Cyclone/Air wash media reclaimer**

The media screen inside the media reclaimer can accumulate debris therefore it should be periodically checked and cleaned. It can be accessed through the access door (#44).

### **4.4 Dust collector**

#### **4.4.1 Wet filtration**

When operating with wet filtration the water in the dust collector becomes contaminated with spent media, therefore the water should be drained regularly. The ideal time to do so is at the end of the work day before the dust has settled to the bottom. This is accomplished by opening the drain ball valve (#46). Refill the dust collector through the 2" connection (#31) until the water level reaches the bottom of the coupling.

#### **4.4.2 Dry filtration**

When operating with dry filtration the spent media accumulates in the bottom of the dust collector, therefore it must be drained periodically. This is accomplished by removing the drain dust cap (#48).

#### **4.4.3 Dry filter cleaning**

To achieve the longest life of the dry filter it is important that they be serviced regularly. The following methods are recommendations to assist in cleaning BRS dry filters. The first three are for both paper element filters and polyester element filters. However, be aware that the washing method is for polyester element filters only.

##### **4.4.3.1 Manual pulsing**

The first cleaning step should be manual pulsing. This is done by opening the manual pulse ball valve (#40 or #69) to provide a burst of air inside the filter to loosen dust particles from the pleated surface. Also manual pulse during periods of blast stoppage.

##### **4.4.3.2 Vacuuming method**

The second cleaning method to utilize is vacuuming. A commercial duty vacuum cleaner

is recommended, but a common household type may also be used. Vacuum the filter from the air intake (contaminated) side only. This procedure will remove the majority of the large particles and surface contaminants that have accumulated and may be sufficient for the first cleaning of the filter. This step should also be performed prior to progressing to any subsequent cleaning method.

#### **4.4.3.3 Compressed air method**

The third cleaning step is by use of compressed air. The air flow must be directed from the opposite direction of the normal air flow through the filter. The air flow should be directed up and down the pleats. Do not direct the flow in a criss-crossing pattern across the direction of the pleats this could cause damage to paper element filters and decreases cleaning efficiency.

#### **4.4.3.4 Washing method (polyester element filter only)**

The washing process is for polyester element filters only. The final cleaning process may be necessary to reduce the static pressure to an acceptable level when the filter has fine particles that have become imbedded in the filter element. For this procedure a mild low sudsing detergent should be used with clean warm water. Soak the filter for 5-10 minutes, then gently agitate the filter for several minutes. The filter should then be thoroughly rinsed with clean water to remove the detergent. It may require a second or third washing to obtain satisfactory filtration. However, the dirt holding capacity of the filter decreases after each washing.

**Critical:** Do not attempt to wash dry filters with paper elements, this will render them useless. If you are not certain of the type of element seek assistance.

**Note:** Polyester element filters can be washed and reused under proper conditions. However, Axxiom / Schmidt has no control over the washing process and cannot guarantee that it has been performed properly and effectively, therefore our warranty does not apply to washed filters.

#### **4.4.3.5 Inspection**

Inspecting the filter after each cleaning is vital. A simple method of inspection is to use a light bulb. Light passing through the filter will reveal fatigued paper or dirt accumulations. Inspection should also include the end plates to check for possible damages during handling. Inspect for damage that could allow contaminated air to bypass the filter element.

### **4.5 Vacuum Head**

As the inner and outer brushes of the vacuum head wear they will lose their sealing capabilities, therefore they should be replaced after approximately 25 hours of use. In addition, the vacuum head contains an inner wear tube to prevent the abrasive from wearing through the body of the vacuum head. This wear tube should be inspected periodically and replaced after approximately 25 hours of use. Refer to drawings on page #5-15.

### **4.6 Remaining Components**

Most of the BRS components are subject to wear and therefore it is expected that they will eventually require maintenance, but those not mentioned above should not need to be part of a periodic maintenance program.

## 5.0 PARTS LIST

This section contains a parts breakdown covering all the major components which may require maintenance during operation of the BRS. The major items identified in the parts list are found on the drawings on pages #5-3 thru #5-15. Refer to these drawings as needed while reading this manual. In addition, repair kits to rebuild these items are identified and drawings are provided to aid in disassembly and installation of the new parts.

<u>ITEM</u>	<u>PART NUMBER</u>	<u>DESCRIPTION</u>
1.	2401-509	Ball valve, full port 2"
2.	1200-999-23	Moisture separator, 2" x 2"
3.	2401-502	Ball valve, full port 1/4"
4.	2010-009-01	Pressure gauge, 0-160 psi
5.	2223-000	Combo valve, 1-1/4"
6.	4104-005	Hose, 4-ply 3/4" (specify length)
7.	2401-507	Ball valve, full port 1-1/4"
8.	2010-009-01	Pressure gauge, 0-160 psi
9.	2401-507	Ball valve, full port 1-1/4"
10.	2003-007	Air regulator, 1-1/4"
11.	2401-507	Ball valve, full port 1-1/4"
12.	2149-107	Thompson valve, urethane 1-1/4"
13.	2263-000	Deadman valve, pneumatic
14.	2025-010	Abrasive cutoff switch, pneumatic
15.	2229-000	Control valve, pneumatic
16.	2229-000	Control valve, pneumatic
17.	2401-507	Ball valve, full port 1-1/4"
	2401-509*	Ball valve, full port 2" *
18.	2018-011	Eductor, urethane 3"
19.	2018-111-01	Eductor nozzle, 150 cfm
	2018-211-01	Eductor nozzle, 225 cfm
	2018-311-01	Eductor nozzle, 350 cfm
	2018-411-01	Eductor nozzle, 440 cfm
20.	2011-011	Muffler assembly, 3"
21.	8031-020-04	BRS 2.0 cyclone media reclaimer
	8031-030-04	BRS 3.5 cyclone media reclaimer
	8031-060-04	BRS 6.5 cyclone media reclaimer
	8031-020-05	BRS air wash media reclaimer
22.	8031-000-34	BRS cyclone reclaimer media screen
	8031-000-75	BRS adjustable air wash reclaimer media screen
23.	8031-020-01	BRS 2.0 cf pressure vessel
	8031-030-01	BRS 3.5 cf pressure vessel
	8031-060-01	BRS 6.5 cf pressure vessel
24.	2100-010	Pop-up head, 3 & 6 bag vessel
25.	2100-011	Pop-up gasket, 3 & 6 bag vessel
26.	8031-020-02	BRS 2.0 dust collector
	8031-030-02	BRS 3.5 & 6.5 dust collector
27.	8031-000-68	BRS demister filter, 18" X 18"
	8031-000-12	BRS demister filter, 24" X 24"
28.	8031-000-40	BRS hepa filter, 18" x 18"
	8031-000-11	BRS hepa filter, 24" x 24"
29.	8031-000-05	BRS filter retractable locator
30.	4222-409	Camlock coupling, type f 2"
31.	4223-409	Camlock coupling, type dc 2"
32.	8031-000-09	BRS dry filter, 12" polyester element
	8031-000-24	BRS dry filter, 12" paper element
	8031-000-83	BRS dry filter, 12" high output
33.	8031-000-10	BRS dry filter, 18" polyester element
	8031-000-25	BRS dry filter, 18" paper element
34.	2010-026	Pressure gauge, 30 vac-0-15 psi

\*On units manufactured prior to June, 1998 vacuum pump air supply valve (#17) was 2".

35.	8031-000-17	BRS pulse air control box
36.	2123-106	Automatic air valve, n.c. 1"
	2123-107	Automatic air valve, n.c. 1-1/4"
37.	2401-502	Ball valve, full port 1/4"
38.	2302-102-05	Air filter, 1/4" 5 micron
39.	2001-010	Regulator, non-adjustable 1/4"
40.	2401-507	Ball valve, full port 1-1/4"
41.	2020-013	Vibrator, 2.0 vessel
	2020-025	Vibrator, 3.5 & 6.5 vessel
42.	2430-804	Angle valve, 1/4"
43.	7000-001-11	Handway crab assembly, 6" x 8"
	7000-001-06	Handway gasket, 6" x 8"
	7000-000-11+	Handway crab assembly, 4" x 6" +
	7000-000-06+	Handway gasket, 4" x 6" +
44.	8031-000-77	BRS 2.0 cyclone reclaimer door gasket
	8031-000-31	BRS 3.5 & 6.5 cyclone reclaimer door gasket
	8031-000-71	BRS air wash reclaimer door gasket
45.	8031-000-70	BRS 2.0 dust collector door gasket
	8031-000-04	BRS 3.5 & 6.5 dust collector door gasket
46.	2401-507	Ball valve, full port 1-1/4"
47.	4222-411	Camlock coupling, type f 3"
	4222-413	Camlock coupling, type f 4"
48.	4223-411	Camlock coupling, type dc 3"
	4223-413	Camlock coupling, type dc 4"
49.	2301-902-90	Strainer, bronze 1/4" 90 micron
50.	8030-000-01	BRS vacuum head, 3" style I
	8030-000-02	Vacuum head inner brush
	8030-000-03	Vacuum head outer brush
	8030-000-05	Vacuum head center tube
51.	5000-xxx	Blast nozzle (specify size)
52.	8031-000-69	BRS 2.0 dust collector head gasket
	8031-000-03	BRS 3.5 & 6.5 dust collector head gasket
53.	4212-010	K.C. nipple, 2-1/2"
	4212-011	K.C. nipple, 3"
54.	4104-40x-0x	Blast hose (specify size and length)
	8031-000-32	BRS threaded nozzle holder (to fit item #50)
55.	8031-000-28	BRS blowdown orifice
56.	8031-000-27	BRS filter wingnut
57.	4224-300-02	Quick connect plug, 1/4"
	4224-301-02	Quick connect socket, 1/4"
58.	2123-107	Automatic air valve, n.c. 1-1/4"
59.	8031-000-18	BRS pulse air pneumatic oscillator
60.	2229-000	Control valve, pneumatic
61.	2020-013	Vibrator, media screen
62.	8031-000-67	BRS dry filter, 10" polyester element
	8031-000-41	BRS dry filter, 10" paper element
63.	2430-804	Angle valve, 1/4"
64.	8031-000-36	BRS vacuum workhead, 3" style II
	8031-000-37	Vacuum workhead brush, 3"
	8031-000-43	Vacuum workhead insert sleeve, 2" lg.
	8031-000-44	Vacuum workhead insert sleeve, 3" lg.
	8031-000-45	Vacuum workhead insert sleeve, 4" lg.
65.	8031-000-42	BRS vessel screen knob
66.	8031-000-46	BRS screen isolator
67.	-----	Pulse air reservoir
68.	2401-502	Ball valve, full port 1/4"
69.	2403-302	Ball valve, 3-way 1/4"

+On units manufactured prior to November, 1996 handway (#43) was 4" x 6".

\*OPTIONAL FEATURES

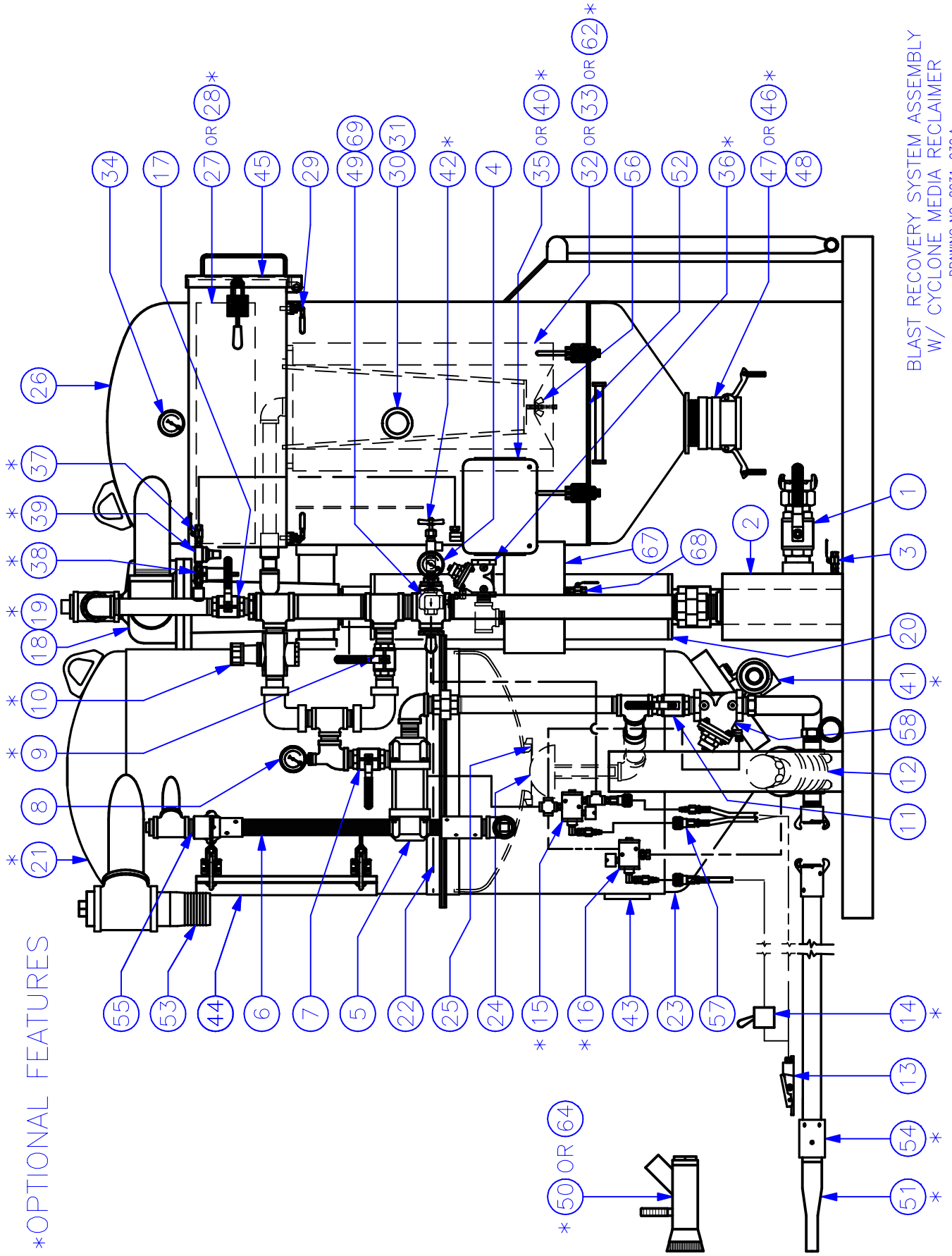

BLAST RECOVERY SYSTEM ASSEMBLY  
W/ CYCLONE MEDIA RECLAIMER  
DRAWING NO. 8031-030.A

\*OPTIONAL FEATURES

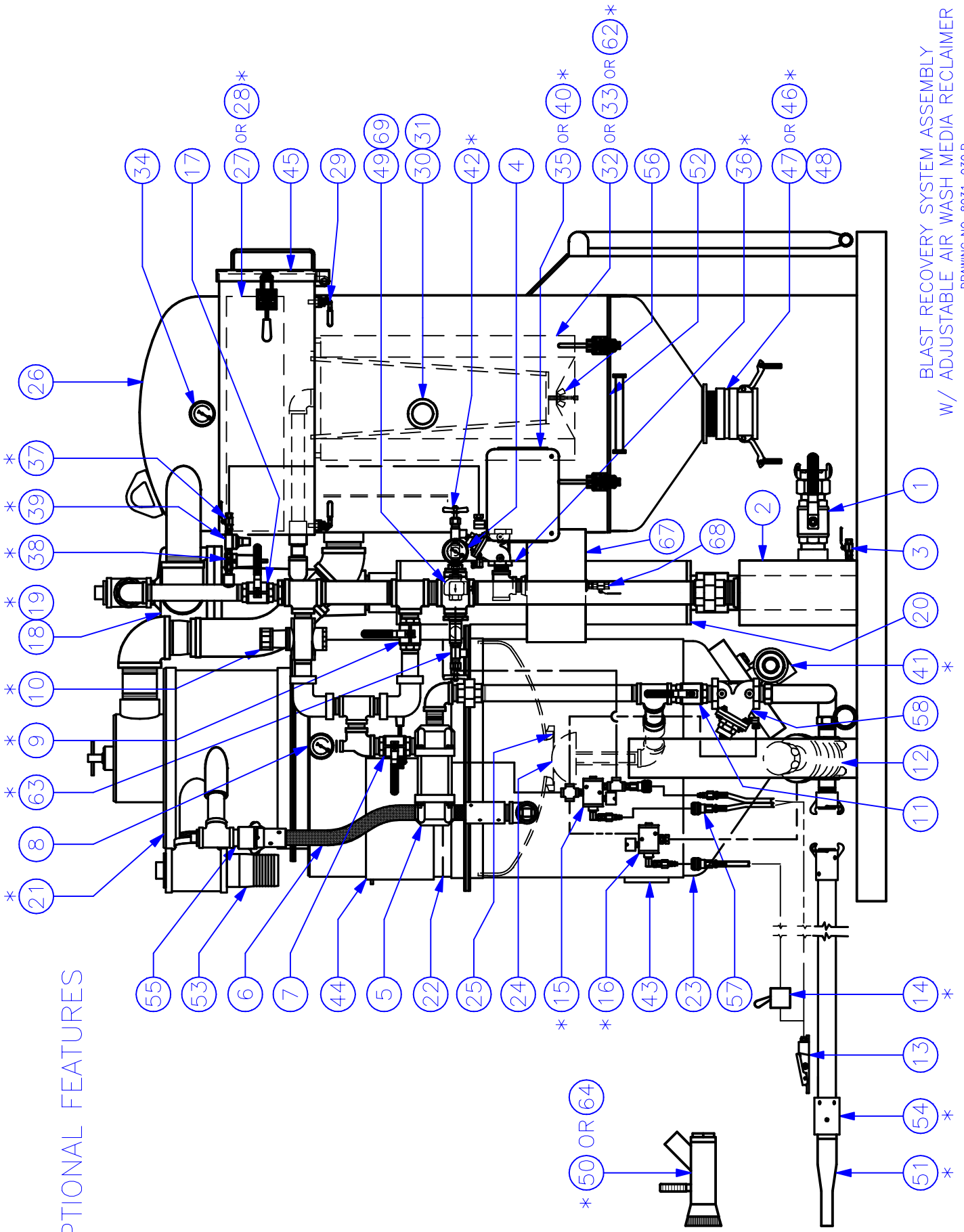

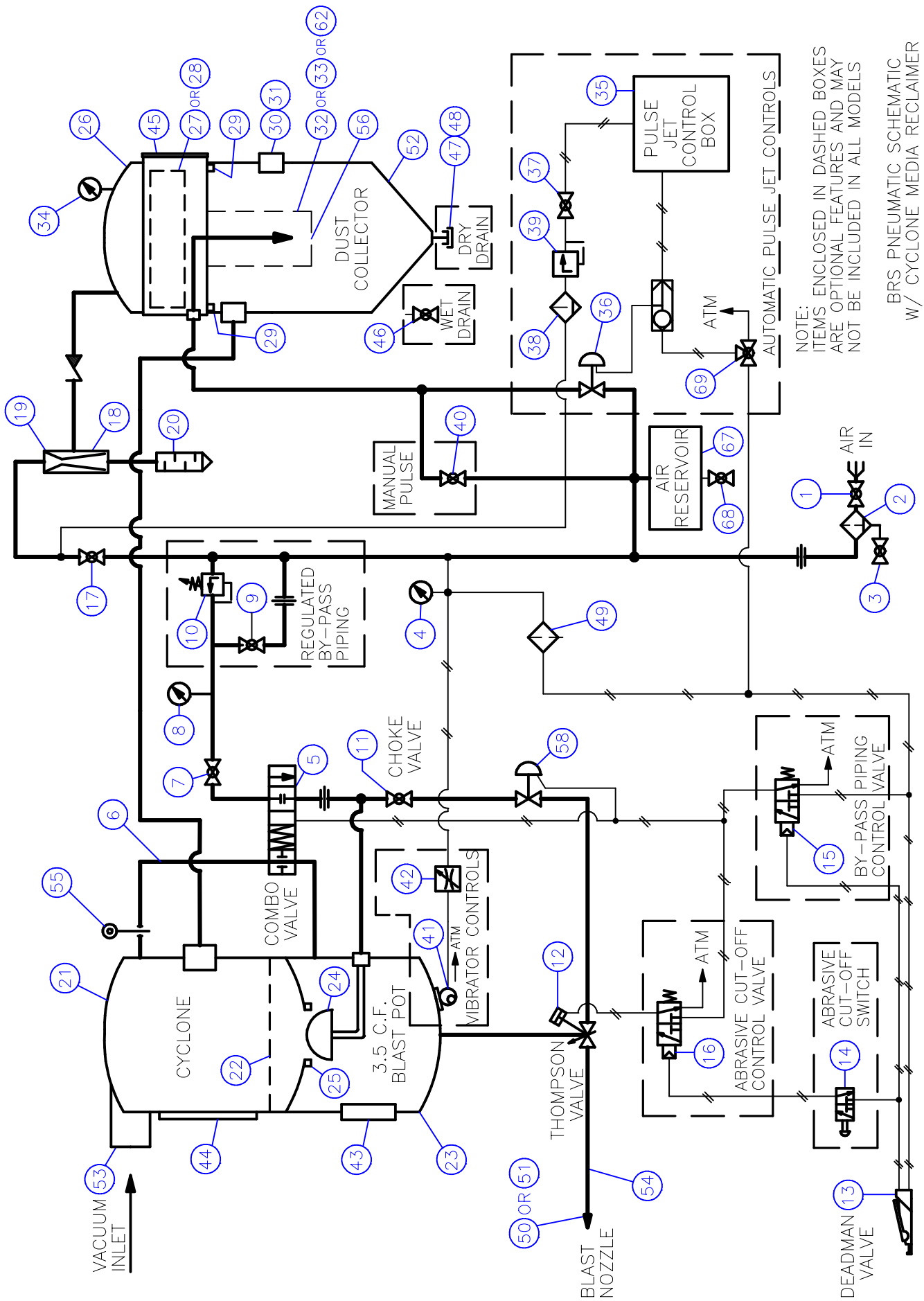

NOTE: ITEMS ENCLOSED IN DASHED BOXES ARE OPTIONAL FEATURES AND MAY NOT BE INCLUDED IN ALL MODELS

BRS PNEUMATIC SCHEMATIC  
W/ CYCLONE MEDIA RECLAIMER  
DRAWING NO. 8031-030.C

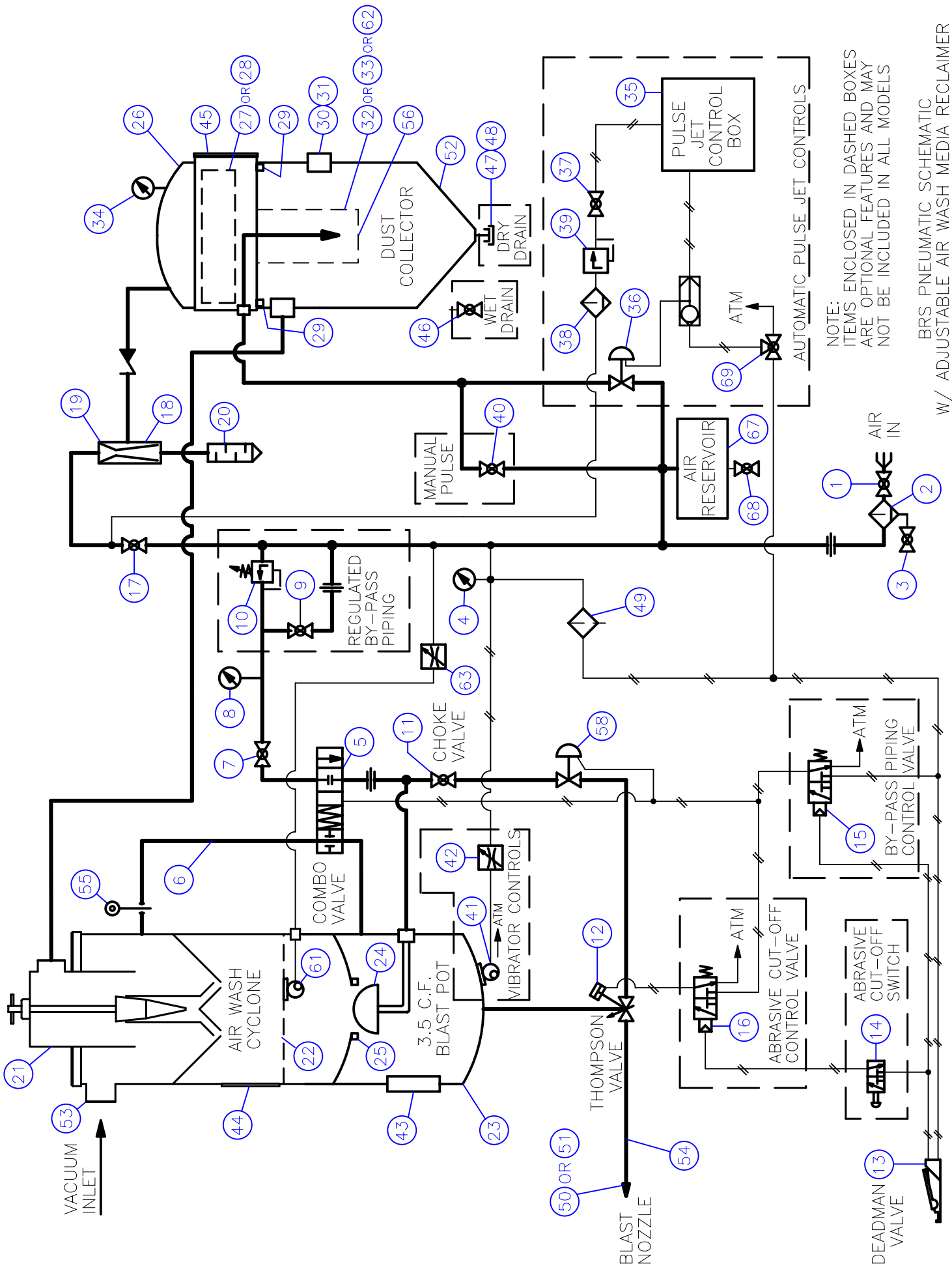

NOTE:  
 ITEMS ENCLOSED IN DASHED BOXES  
 ARE OPTIONAL FEATURES AND MAY  
 NOT BE INCLUDED IN ALL MODELS

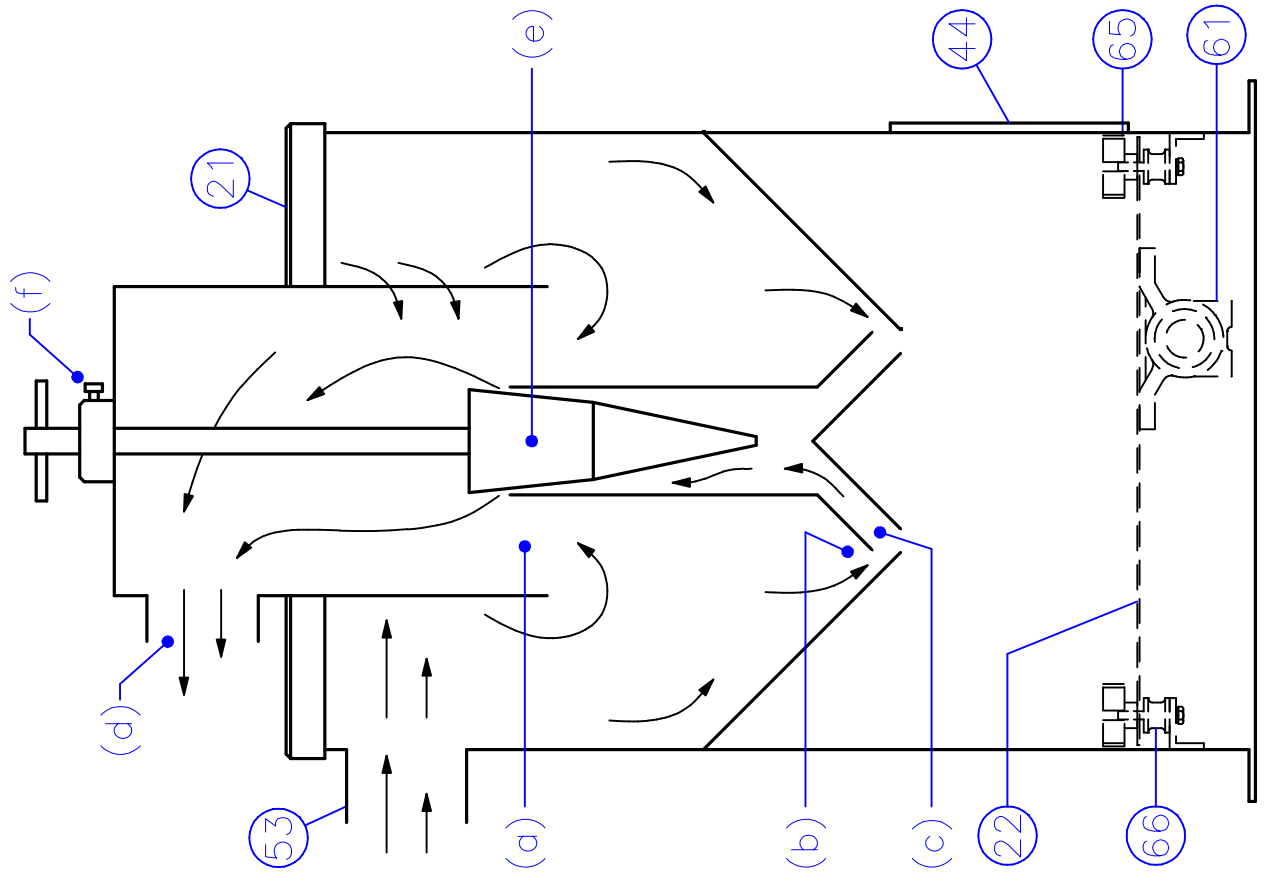

ADJUSTABLE AIRWASH MEDIA RECLAIMER

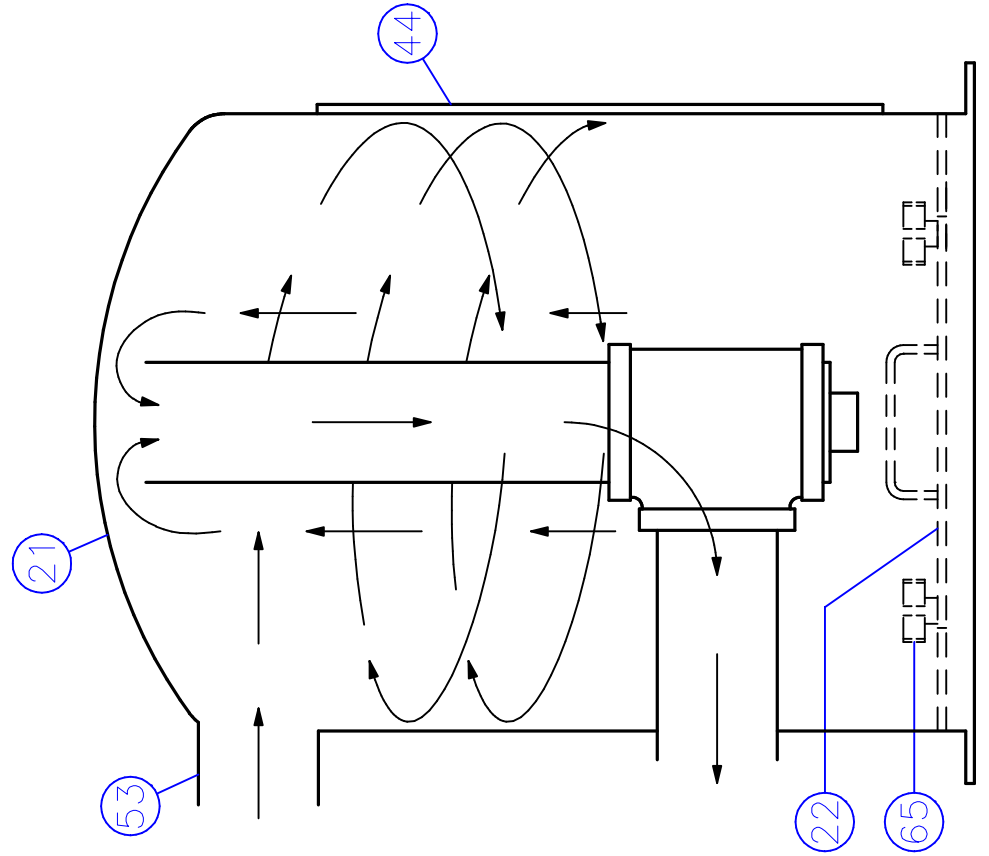

CYCLONE MEDIA RECLAIMER

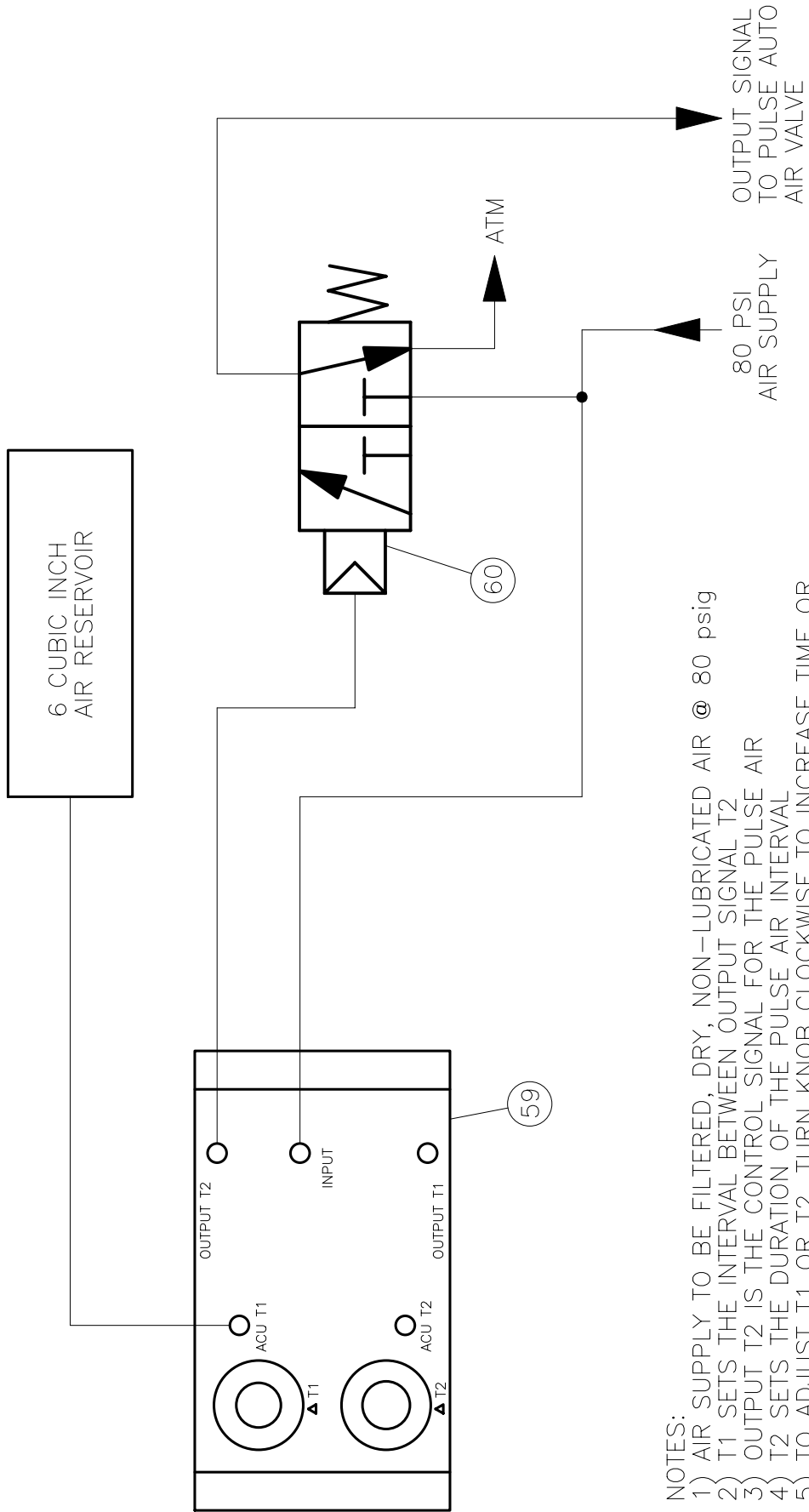

- NOTES:
- 1) AIR SUPPLY TO BE FILTERED, DRY, NON-LUBRICATED AIR @ 80 psig
  - 2) T1 SETS THE INTERVAL BETWEEN OUTPUT SIGNAL T2
  - 3) OUTPUT T2 IS THE CONTROL SIGNAL FOR THE PULSE AIR
  - 4) T2 SETS THE DURATION OF THE PULSE AIR INTERVAL
  - 5) TO ADJUST T1 OR T2, TURN KNOB CLOCKWISE TO INCREASE TIME OR COUNTER-CLOCKWISE TO DECREASE TIME

# Combo Valve

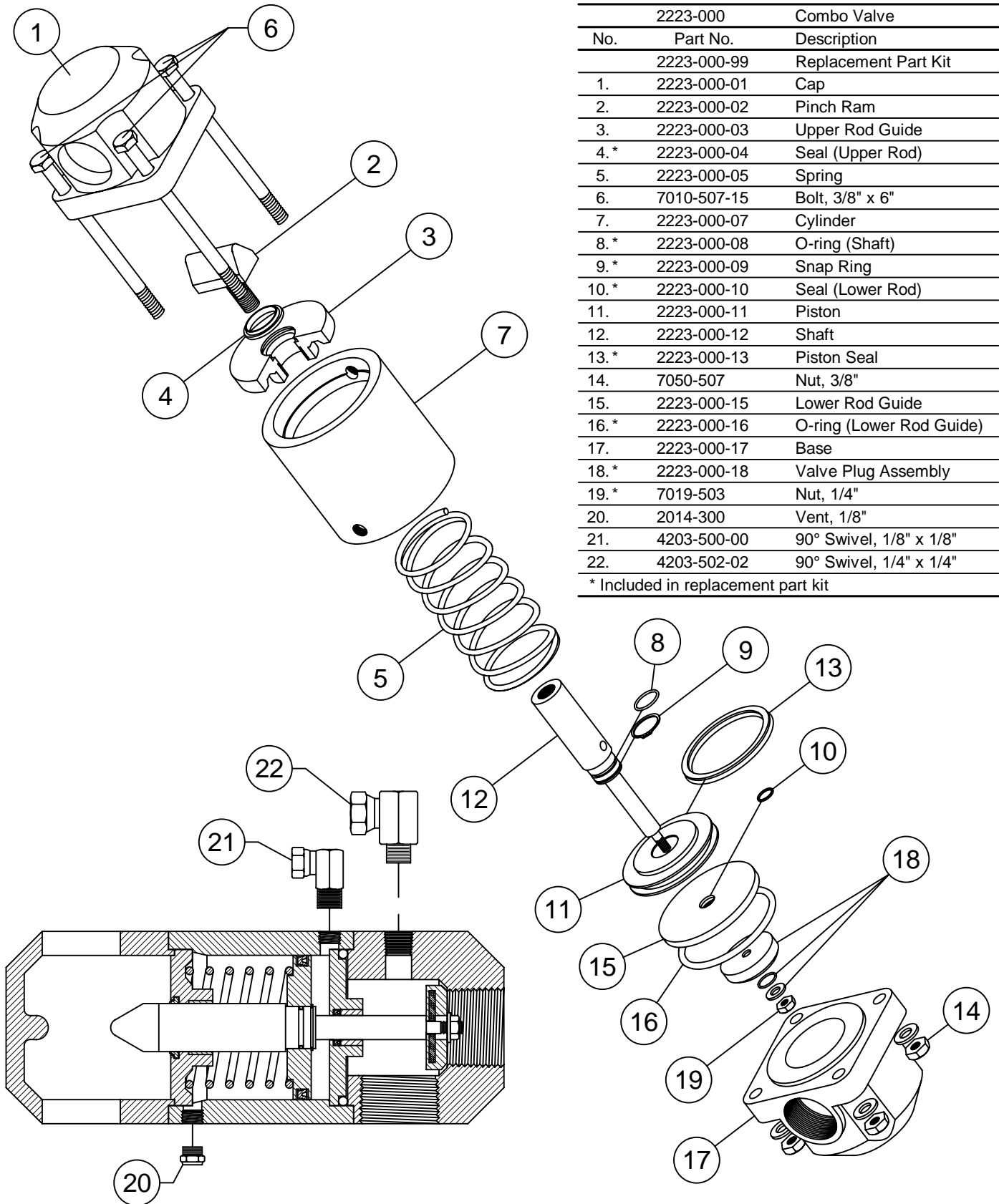

No.	Part No.	Description
	2223-000	Combo Valve
	2223-000-99	Replacement Part Kit
1.	2223-000-01	Cap
2.	2223-000-02	Pinch Ram
3.	2223-000-03	Upper Rod Guide
4.*	2223-000-04	Seal (Upper Rod)
5.	2223-000-05	Spring
6.	7010-507-15	Bolt, 3/8" x 6"
7.	2223-000-07	Cylinder
8.*	2223-000-08	O-ring (Shaft)
9.*	2223-000-09	Snap Ring
10.*	2223-000-10	Seal (Lower Rod)
11.	2223-000-11	Piston
12.	2223-000-12	Shaft
13.*	2223-000-13	Piston Seal
14.	7050-507	Nut, 3/8"
15.	2223-000-15	Lower Rod Guide
16.*	2223-000-16	O-ring (Lower Rod Guide)
17.	2223-000-17	Base
18.*	2223-000-18	Valve Plug Assembly
19.*	7019-503	Nut, 1/4"
20.	2014-300	Vent, 1/8"
21.	4203-500-00	90° Swivel, 1/8" x 1/8"
22.	4203-502-02	90° Swivel, 1/4" x 1/4"

\* Included in replacement part kit

# Control Valves

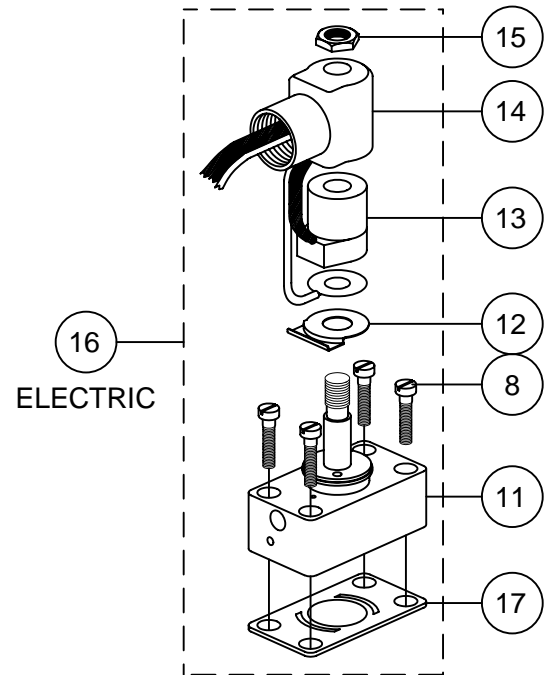
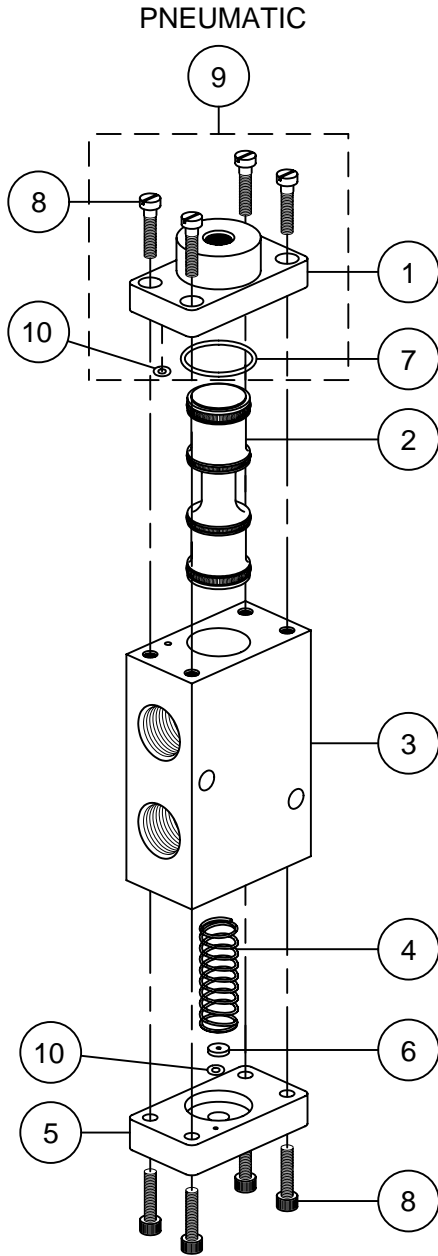

	2229-000	Pneumatic Control Valve
	2229-100	Electric Control Valve-12 Volt D.C.
	2229-101	Electric Control Valve-12 Volt A.C.
	2229-102	Electric Control Valve-24 Volt D.C.
	2229-103	Electric Control Valve-24 Volt A.C.
	2229-105	Electric Control Valve-120 Volt A.C.
No.	Part No.	Description
	2229-000-99	Replacement Part Kit (Pneumatic)
	2229-100-99	Replacement Part Kit (Electric)
1.	Not Available	Air Operator Cap
2.*	2229-000-02	Plunger w/O-Ring
3.	Not Available	Valve Body
4.*	2229-000-04	Spring
5.	Not Available	Spring Retainer
6.*	2229-000-06	Filter Disk
7.*	2229-000-07	O-Ring
8.	Not Available	Screw (8)
9.	2229-000-09	Air Operator Assembly
10.*	2229-000-10	O-Ring (2 ea)
11.	Not Available	Electric Operator Cap
12.	Not Available	Coil Cover Bottom
13.	2229-100-03	Coil 12 Volt D.C.
	2229-101-03	Coil 12 Volt A.C.
	2229-102-03	Coil 24 Volt D.C.
	2229-103-03	Coil 24 Volt A.C.
	2229-105-03	Coil 120 Volt A.C.
14.	Not Available	Coil Cover
15.	Not Available	Nut
16.	2229-100-06	Solenoid Pilot Assembly-12 Volt D.C.
	2229-101-06	Solenoid Pilot Assembly-12 Volt A.C.
	2229-102-06	Solenoid Pilot Assembly-24 Volt D.C.
	2229-103-06	Solenoid Pilot Assembly-24 Volt A.C.
	2229-105-06	Solenoid Pilot Assembly-120 Volt A.C.
17.+	2229-100-07	Gasket (Electric Only)
* Included In Replacement Part Kit-Pneumatic		
+ Included In Replacement Part Kit-Electric		

# Pneumatic Deadman Controls

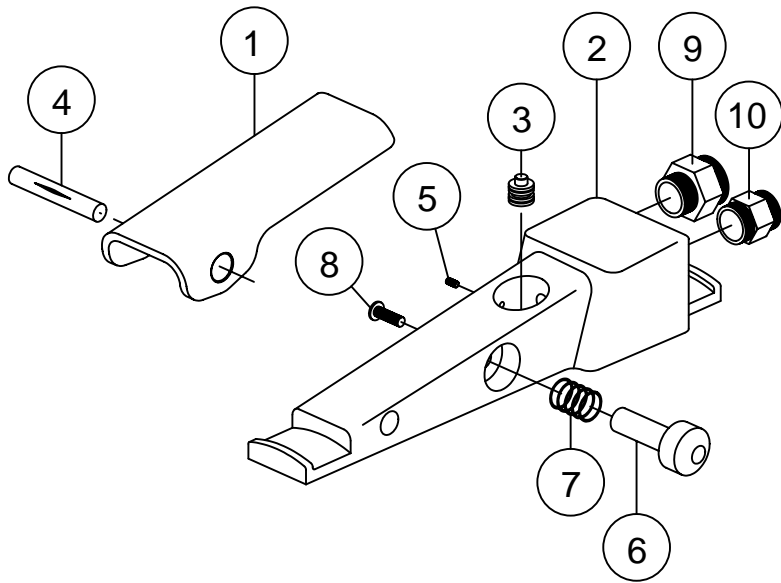

2263-000 Pneumatic Deadman		
No.	Part No.	Description
2263-000-99 Replacement Part Kit		
1.	2263-000-01	Lever
2.	2263-000-02	Body
3.*	2263-000-03	Cartridge
4.	2263-000-04	Hinge Pin
5.*	2263-000-05	Set Screw
6.	2263-000-06	Button
7.*	2263-400-07	Spring
8.*	2263-400-08	Screw for Button
9.	3031-302-00	Hex Nipple, 1/8" x 1/4"
10.	3031-300-00	Hex Nipple, 1/8" x 1/8"

\* Included in replacement part kit

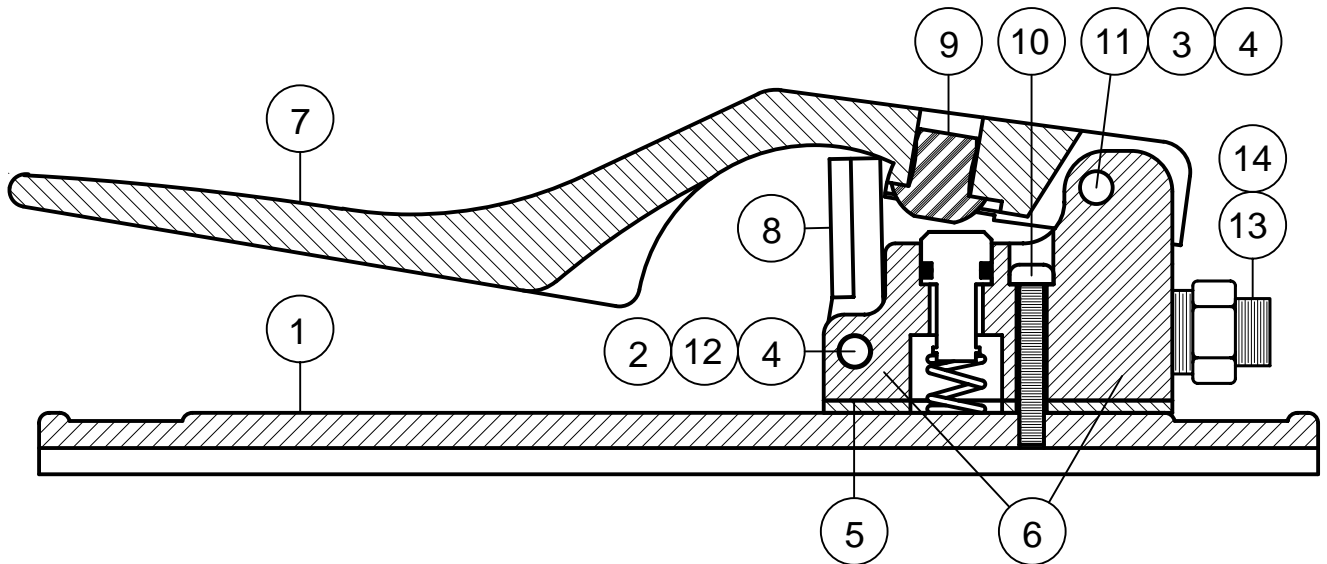

2263-000 Pneumatic Deadman II					
No.	Part No.	Description	No.	Part No.	Description
2263-001-99 Replacement Part Kit			8.	2263-001-08	Safety Flap
1.	2263-001-01	Base	9.*	2263-001-09	Plunger Screw
2.	2263-001-02	Safety Flap Spring	10.	2263-001-10	Body Mounting Screw
3.	2263-001-03	Lever Hinge Screw	11.	2263-001-11	Lever Spring
4.	2263-001-04	Hinge Pin Nut	12.	2263-001-12	Flap Hinge Screw
5.*	2263-001-05	Body Gasket	13.	3031-302-00	Hex Nipple, 1/8" x 1/4"
6.*	2263-001-06	Valve Body Assembly	14.	3031-300-00	Hex Nipple, 1/8" x 1/8"
7.	2263-001-07	Lever			

\* Included in replacement part kit

# G2 PNEUMATIC DEADMAN

Item	Part No.	Description
	2263-002	G2 Pneumatic Deadman
	2263-002-99	G2 Replacement Parts Kit
1.	2263-002-01	G2 Deadman Lever
2.	2263-002-02	G2 Deadman Body
*3.	2263-002-03	G2 Deadman Cartridge Assembly
4.	2263-002-04	G2 Deadman Hinge Pin
*5.	2263-002-05	G2 Deadman Cartridge Set Screw
6.	2263-002-06	G2 Deadman Button
*7.	2263-002-07	Deadman Spring
*8.	2263-000-08	Deadman Screw For Button
9.	3031-300-00	Hex Nipple, 1/8" x 1/8" With Ball Seat
10.	3031-302-02	Hex Nipple, 1/4" x 1/4" With Ball Seat

\*Items included in Replacement Parts Kit

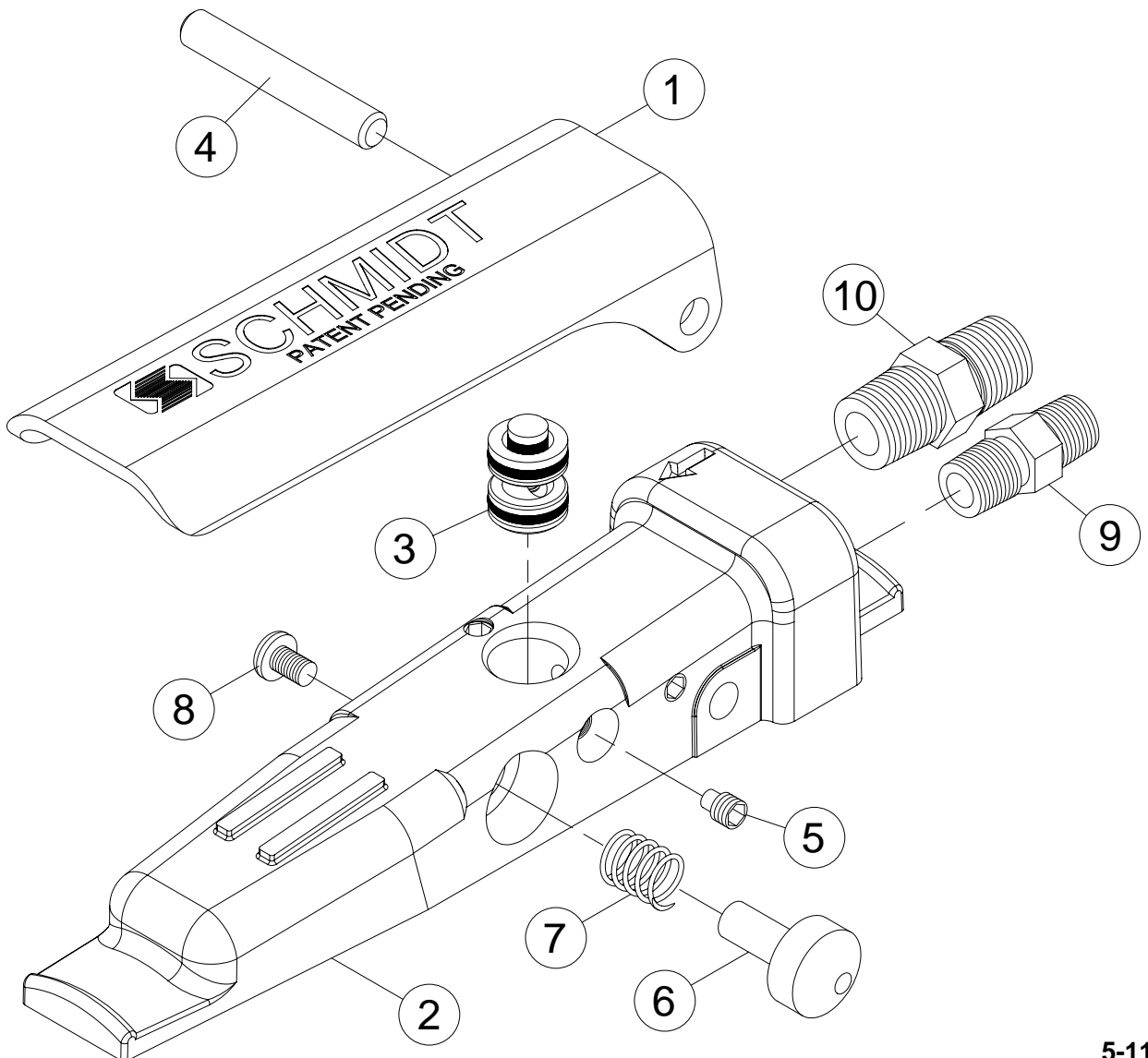

# Electric Deadman Controls

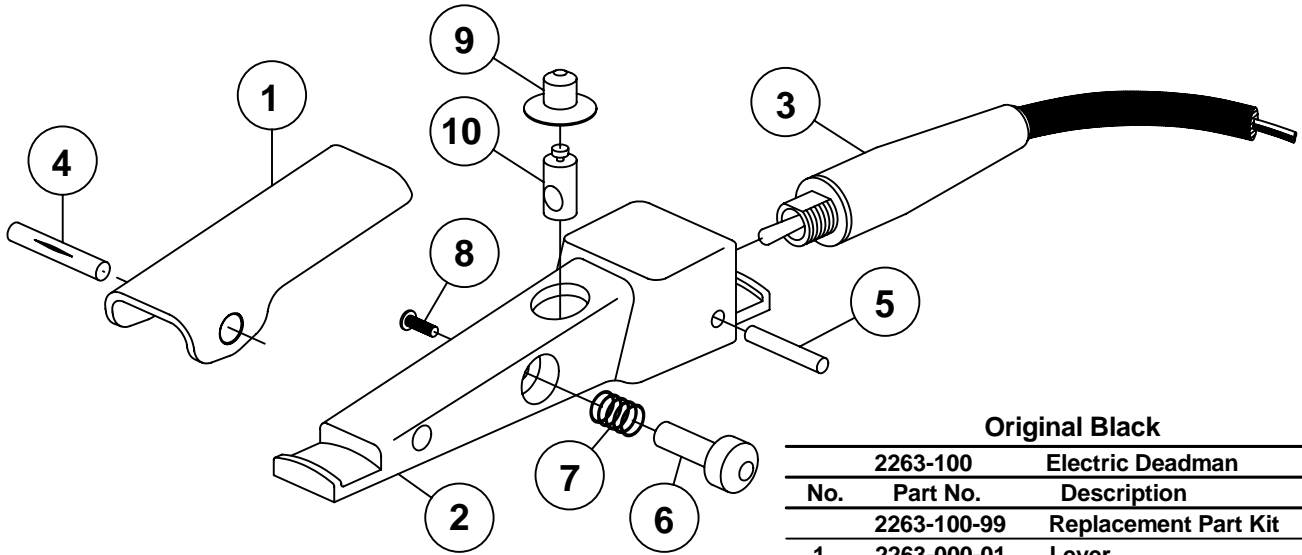

## Original Black

No.	Part No.	Description
	2263-100	Electric Deadman
	2263-100-99	Replacement Part Kit
1.	2263-000-01	Lever
2.	2263-000-02	Body
3.*	2263-000-03	Switch
4.	2263-000-04	Hinge Pin
5.*	2263-000-05	Switch Lock Pin
6.	2263-000-06	Button
7.*	2263-000-07	Spring
8.*	2263-000-08	Screw for Button
9.*	2263-000-09	Dust Cover
10.	2263-000-10	Plunger

\* Included in replacement part kit

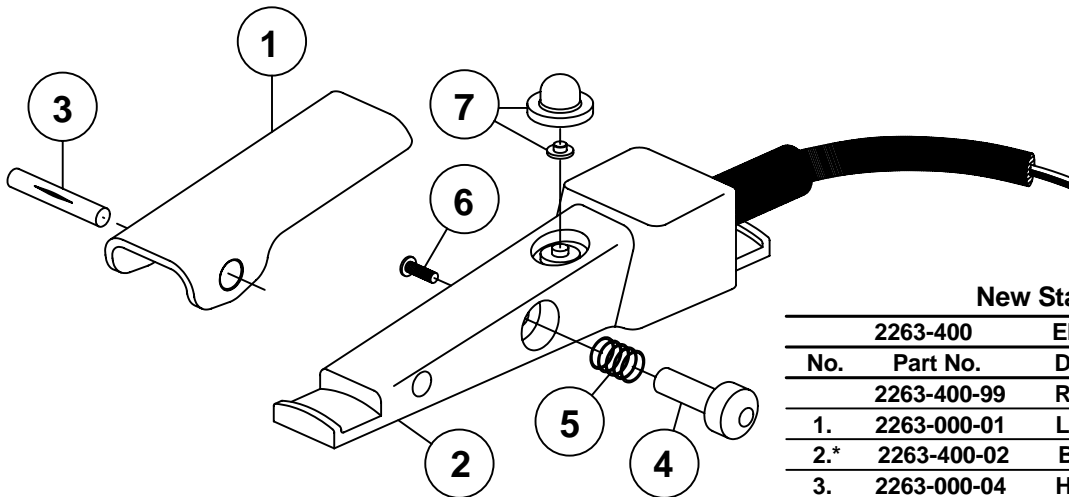

## New Standard

No.	Part No.	Description
	2263-400	Electric Deadman
	2263-400-99	Replacement Part Kit
1.	2263-000-01	Lever
2.*	2263-400-02	Body w/Molded Switch
3.	2263-000-04	Hinge Pin
4.	2263-000-06	Button
5.*	2263-000-07	Spring
6.*	2263-000-08	Screw for Button
7.*	2263-400-09	Dust Cover w/Insert

\* Included in replacement part kit

# Automatic Air Valve (Normally Closed)

2123-106 1" Valve		
No.	Part No.	Description
2123-006-99 Replacement Part Kit		
1.*	2123-006-01	Gasket
2.*	2123-006-02	Diaphragm
3.*	2123-006-03	O-ring
4.	2123-006-04	Retainer Bushing
5.*	2123-006-05	O-ring
6.	2123-006-06	Disk Retainer
7.*	2123-006-07	O-ring
8.	2123-006-08	Seat
9.	2123-006-09	Disc Plate
10.	"Deleted"	Lock Washer, Internal
11.*	2123-006-11	Lock Nut
12.	2123-106-12	Cap
13.*	2123-006-13	Lock Nut
14.	2123-006-14	Cap Screw
15.	2123-006-15	Diaphragm Plate
17.	2123-006-17	Lock Nut
18.	2123-006-18	Body, 1"
19.	2123-006-19	Shaft
20.*	2123-006-20	Gasket
21.*	2123-006-21	Disc
22.	2123-106-22	Gasket
23.	2123-106-23	Spring Retainer
24.	2123-106-24	Spring
25.	2014-300	Vent, 1/8" (not included)

\* Included In Replacement Part Kit

2123-107 1 1/4" Valve		
No.	Part No.	Description
2123-108 1 1/2" Valve		
2123-007-99 Replacement Part Kit		
1.*	2123-007-01	Gasket
2.*	2123-007-02	Diaphragm
3.*	2123-007-03	O-ring
4.	2123-007-04	Retainer Bushing
5.*	2123-007-05	O-ring
6.	2123-007-06	Disk Retainer
7.*	2123-007-07	O-ring
8.	2123-007-08	Seat
9.	2123-007-09	Disc Plate
10.	"Deleted"	Lock Washer, Internal
11.*	2123-007-11	Lock Nut
12.	2123-107-12	Cap
13.*	2123-007-13	Lock Nut
14.	2123-007-14	Cap Screw
15.	2123-007-15	Diaphragm Plate
17.	2123-007-17	Lock Nut
18.	2123-007-18	Body, 1 1/4"
19.	2123-007-19	Shaft
20.*	2123-007-20	Gasket
21.*	2123-007-21	Disc
22.	2123-107-22	Gasket
23.	2123-107-23	Spring Retainer
24.	2123-107-24	Spring
25.	2014-300	Vent, 1/8" (not included)

\* Included In Replacement Part Kit

2123-109 2" Valve		
No.	Part No.	Description
2123-009-99 Replacement Part Kit		
1.*	2123-009-01	Gasket
2.*	2123-009-02	Diaphragm
3.*	2123-009-03	O-ring
4.	2123-009-04	Retainer Bushing
5.*	2123-009-05	O-ring
6.	2123-009-06	Disk Retainer
7.*	2123-009-07	O-ring
8.	2123-009-08	Seat
9.	2123-009-09	Disc Plate
10.	"Deleted"	Lock Washer, Internal
11.*	2123-009-11	Lock Nut
12.	2123-109-12	Cap
13.*	2123-009-13	Lock Nut
14.	2123-009-14	Cap Screw
15.	2123-009-15	Diaphragm Plate
17.	2123-009-17	Lock Nut
18.	2123-009-18	Body, 2"
19.	2123-009-19	Shaft
20.*	2123-009-20	Gasket
21.*	2123-009-21	Disc
22.		Not Needed
23.	2123-109-23	Spring Retainer
24.	2123-109-24	Spring
25.	2014-300	Vent, 1/8" (not included)

\* Included In Replacement Part Kit

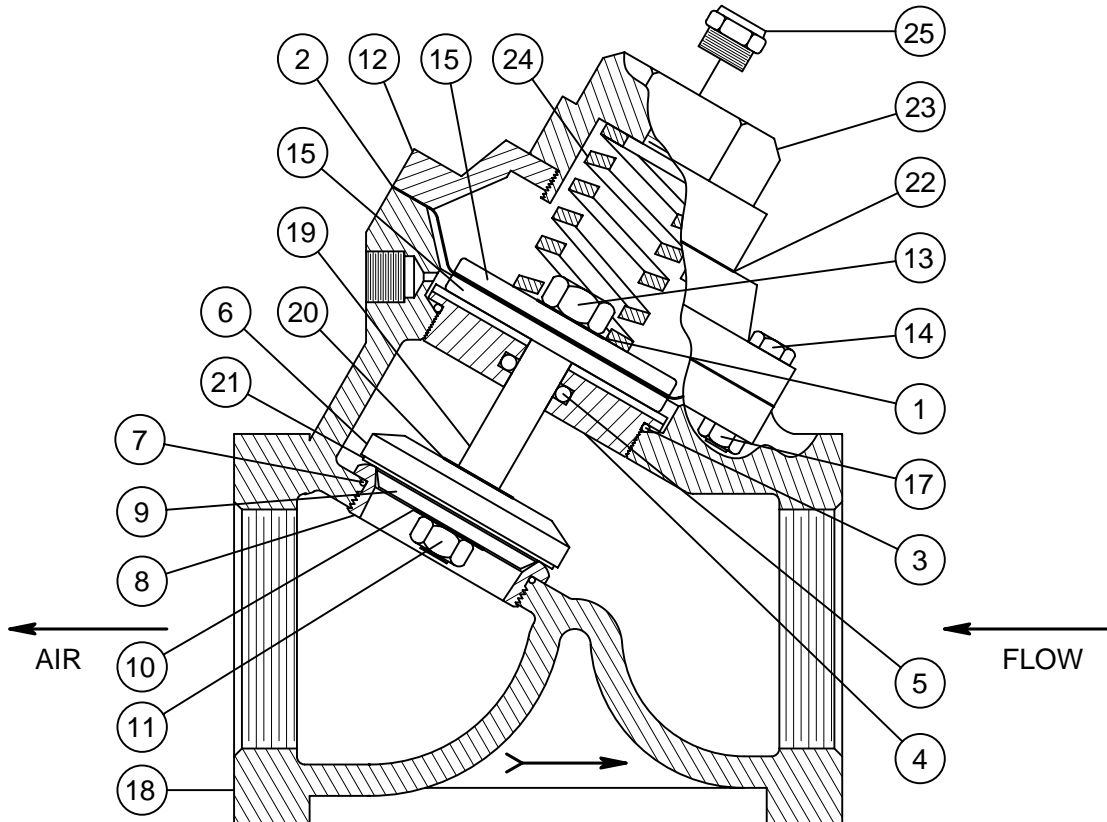

NOTE: With spring closed valve air flow is in opposite direction from arrow on valve body.

# Thompson Valve®

2149-006	1" Valve With Tungsten Carbide Sleeve
2149-106	1" Valve With Urethane Sleeve
2149-007	1 1/4" Valve With Tungsten Carbide Sleeve
2149-107	1 1/4" Valve With Urethane Sleeve
2149-008	1 1/2" Valve With Tungsten Carbide Sleeve
2149-108	1 1/2" Valve With Urethane Sleeve

No.	Part No.	Description
	2149-000-99	Replacement Parts Kit (Tungsten Carbide)
	2149-100-99	Replacement Parts Kit (Urethane Sleeve)
1.	2149-000-01	Knob
2.	2149-000-02	Cap
3.	2149-000-19	Bump Ring
4.	2149-000-03	Spring
5.	2149-000-08	Nut
*+ 6.	2149-000-04	Piston Seal
7.	2149-000-05	Piston
*+ 8.	2149-000-07	Tungsten Carbide Plunger
9.	2149-000-09	Cylinder
*+10.	2149-000-06	Plunger Seal
+11.	2149-100-13	Urethane Sleeve
12.	2149-000-11	Base
13.	7010-507-55	Bolt
14.	2149-006-15	Pipe Nipple, 1" x 8"
	2149-007-15	Pipe Nipple, 1 1/4" x 8"
	2149-008-15	Pipe Nipple, 1 1/2" x 8"
	2149-008-16	Pipe Nipple, 1 1/2" x 36"
*15.	2149-000-18	O-Ring
*16.	2149-000-14	Insert
*17.	2149-000-10	Seat
*18.	2149-000-13	Tungsten Carbide Sleeve
* Included In Replacement Parts Kit For Tungsten Carbide Sleeve		
+ Included In Replacement Parts Kit For Urethane Sleeve		

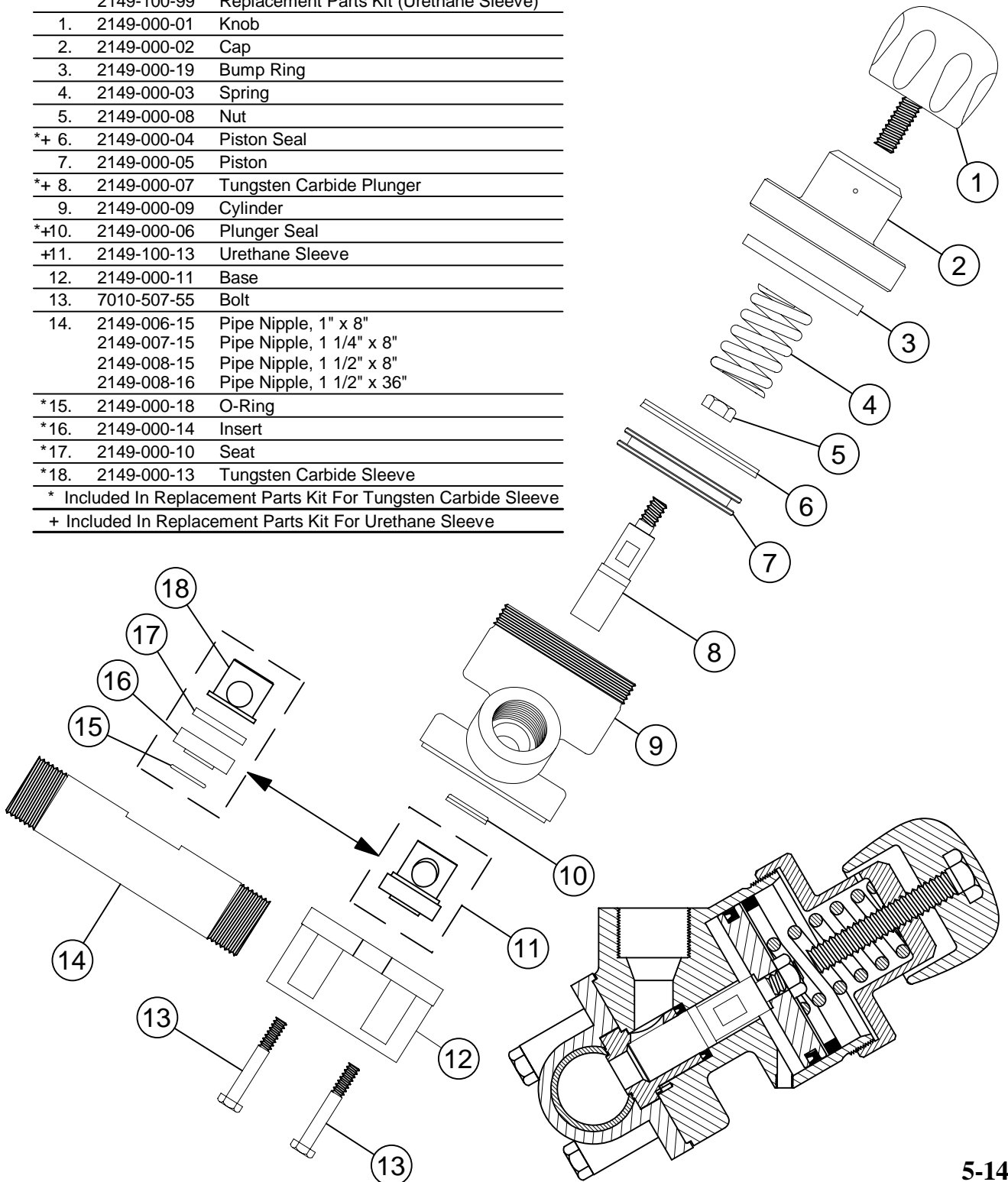

# Thompson Valve® II

	2152-006	1" Valve With Tungsten Carbide Sleeve
	2152-106	1" Valve With Urethane Sleeve
	2152-007	1 1/4" Valve With Tungsten Carbide Sleeve
	2152-107	1 1/4" Valve With Urethane Sleeve
	2152-008	1 1/2" Valve With Tungsten Carbide Sleeve
	2152-108	1 1/2" Valve With Urethane Sleeve
No.	Part No.	Description
	2152-000-99	Replacement Parts Kit (Tungsten Carbide)
	2152-100-99	Replacement Parts Kit (Urethane)
1.	2152-000-01	Knob
2.	2152-000-17	Breather Vent
3.	2152-000-12	Spring Retainer
4.*+	2152-000-18	O-Ring
5.	7027-503-02	Washer
6.	7010-507-07	Hex Bolt, 3/8" UNC x 1-1/4" Lg.
7.	2152-000-02	Cap Plate
8.*+	2152-000-16	Cap Gasket
9.	2149-000-19	Bump Ring
10.	2152-000-25	Vibration Disc
11.	2152-000-03	Spring
12.	2149-000-08	Nut
13.*+	2149-000-04	Piston Seal
14.	2152-000-05	Piston
15.*+	2152-000-07	Tungsten Carbide Plunger
16.	2152-000-09	Cylinder
17.*+	2149-500-06	Plunger Seal (Molythane)
18.*+	2152-000-06	Plunger Seal (Urethane)
19.	2152-000-14	Body
20. +	2152-100-13	Urethane Sleeve
21.	2152-000-19	Base, 1" NPT
	2152-000-15	Base, 1 1/4" NPT
	2152-000-11	Base, 1 1/2" NPT
22.	7010-507-95	Hex Bolt, 3/8" UNC x 4 3/4" Lg.
23.	3014-106	Plug
24.*	2152-000-21	O-Ring
25.*	2152-000-13	Tungsten Carbide Sleeve
26.*	2152-000-10	Seat
27.	8403-000-54	Cleanout Ball Valve Adder
28.	3006-106	Street Elbow 90°, 1" Galv.
29.	3029-106-09	Nipple TBE, 1" x 2" Lg. Galv.
30.	2401-506	Ball Valve, 1" Full Port
* Included In Replacement Part Kit For Tungsten Carbide Sleeve		
+ Included In Replacement Part Kit For Urethane Sleeve		

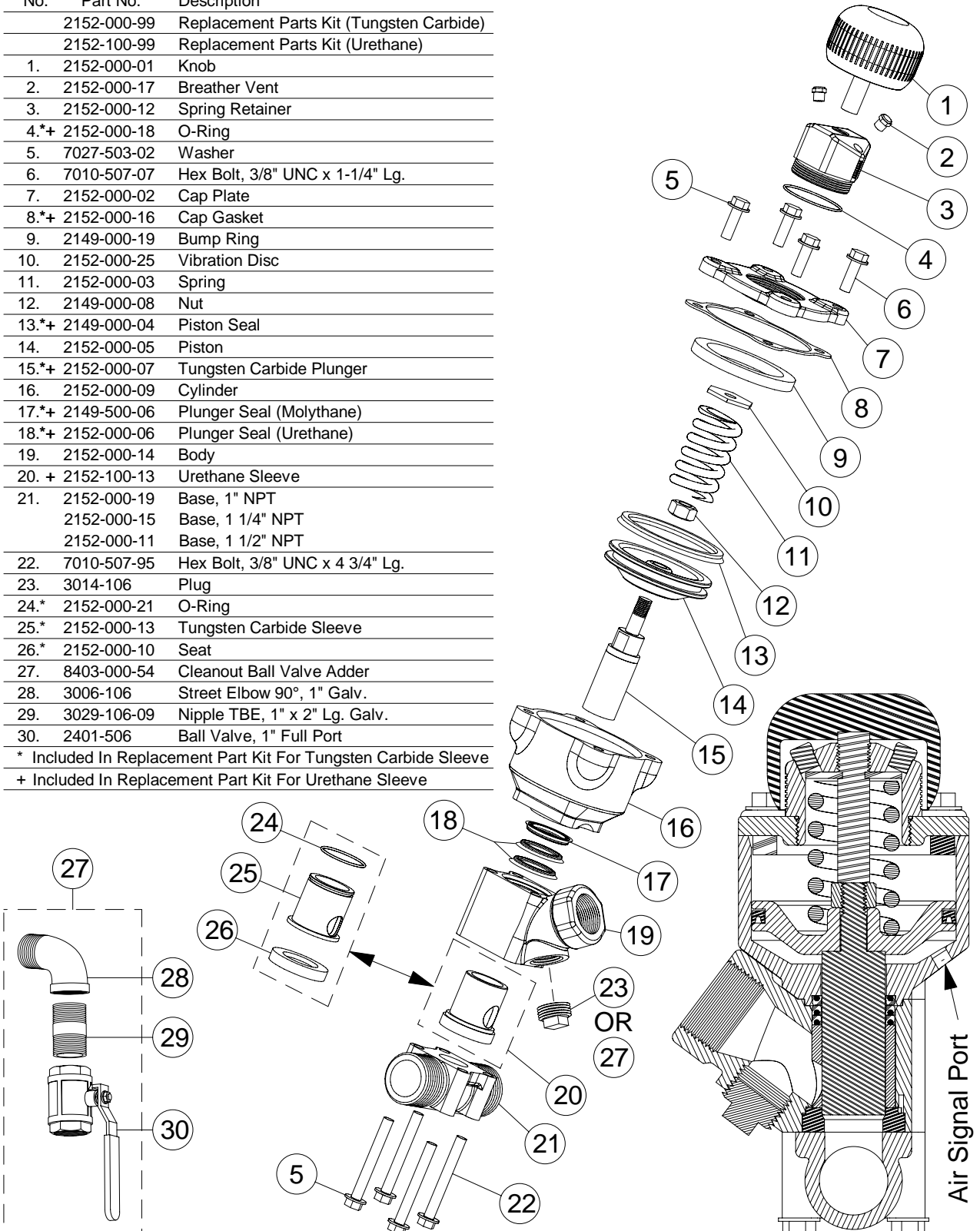

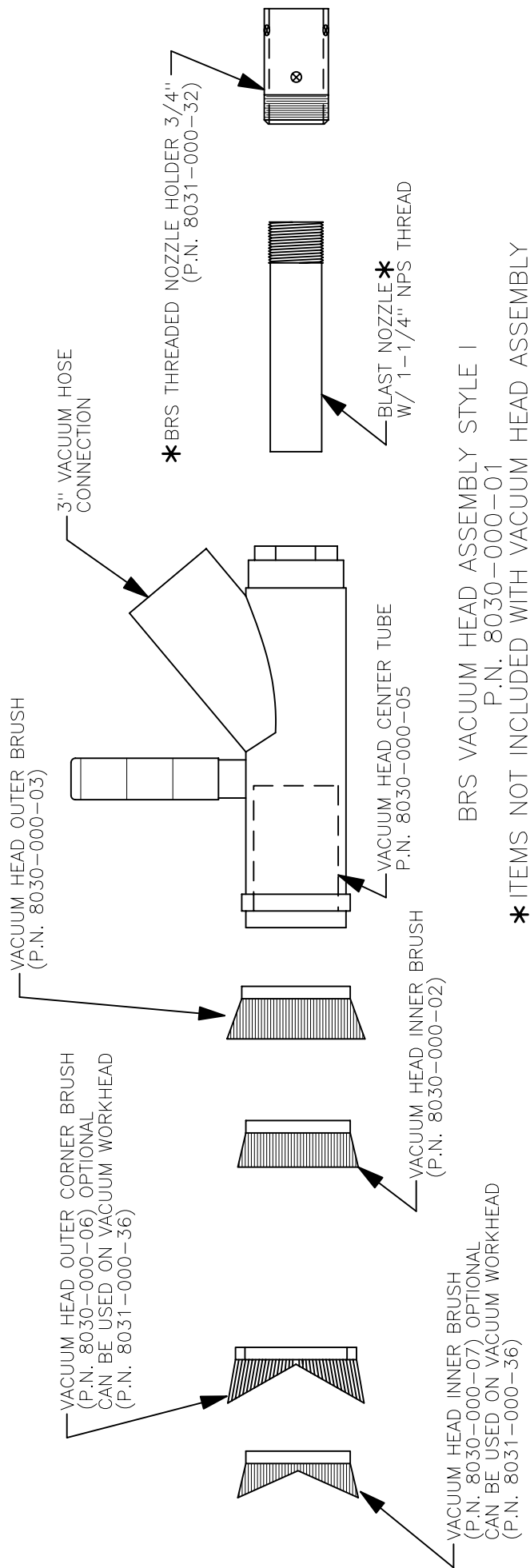

BRS VACUUM HEAD ASSEMBLY STYLE I  
P.N. 8030-000-01

\* ITEMS NOT INCLUDED WITH VACUUM HEAD ASSEMBLY

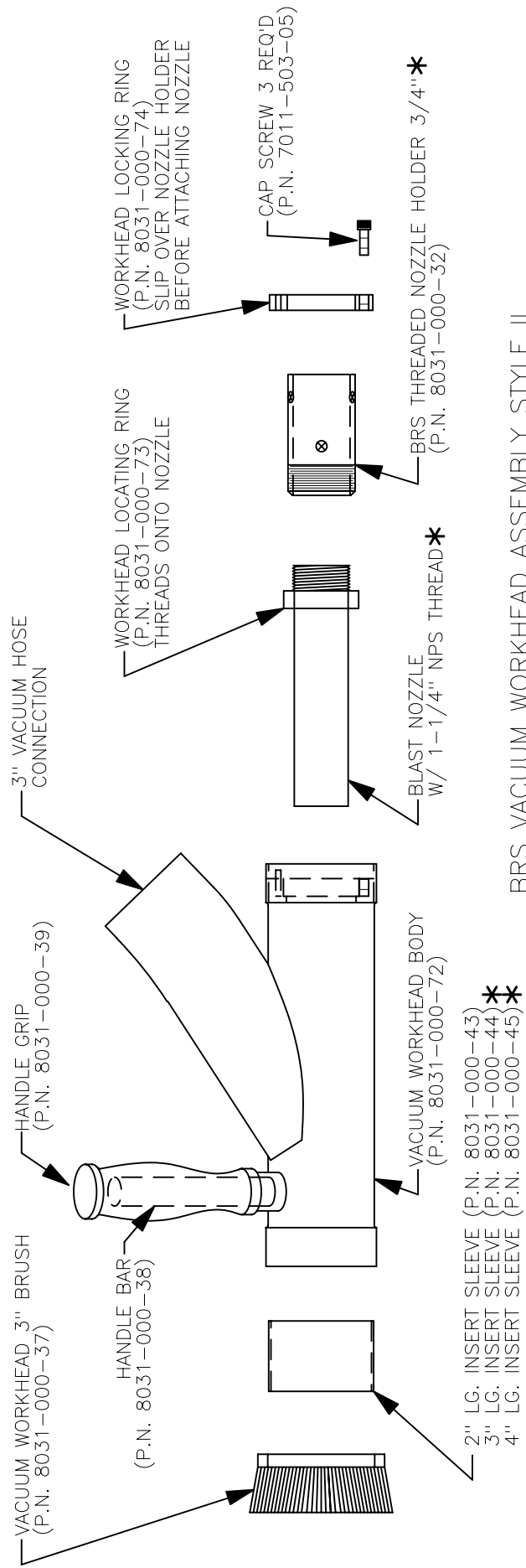

BRS VACUUM WORKHEAD ASSEMBLY STYLE II  
P.N. 8031-000-36

\* ITEMS NOT INCLUDED WITH VACUUM HEAD ASSEMBLY

## 6.0 BLASTING DATA

6.1 **TABLE 1 APPROXIMATE AIR CONSUMPTION (CFM) PER BLAST NOZZLE**

NOZZLE SIZE		NOZZLE PRESSURE						
		60 psi	70 psi	80 psi	90 psi	100 psi	120 psi	140 psi
No.2	1/8"	14	16	18	20	22	26	30
No.3	3/16"	32	36	41	45	49	58	66
No.4	1/4"	57	65	72	80	90	105	121
No.5	5/16"	90	101	113	125	140	160	185
No.6	3/8"	126	145	163	182	200	235	270
No.7	7/16"	170	193	215	240	270	315	360
No.8	1/2"	230	260	290	320	350	410	470
No.10	5/8"	360	406	454	500	550	640	740
No.12	3/4"	518	585	652	720	790	925	1060

6.2 **TABLE 2 ABRASIVE CONSUMPTION (lbs. per hour) PER BLAST NOZZLE**

NOZZLE SIZE		NOZZLE PRESSURE						
		60 psi	70 psi	80 psi	90 psi	100 psi	120 psi	140 psi
No.2	1/8"	90	105	115	130	140	165	190
No.3	3/16"	205	230	260	290	320	375	430
No.4	1/4"	365	420	460	500	560	660	760
No.5	5/16"	575	650	725	825	900	1050	1200
No.6	3/8"	840	945	1050	1155	1260	1475	1700
No.7	7/16"	1150	1300	1450	1600	1750	2050	2350
No.8	1/2"	1460	1660	1850	2000	2250	2650	3000
No.10	5/8"	2290	2600	2900	3125	3520	4100	4750
No.12	3/4"	3300	3750	4180	4500	5060	5950	6800

6.3 **TABLE 3 HOSE SELECTION GUIDE (BLASTING @ 100 psi)**

NOZZLE SIZE	No.4 1/4"	No.5 5/16"	No.6 3/8"	No.7 7/16"	No.8 1/2"
CFM @ 100psi	90	140	200	270	350
AIR HOSE	1 1/4"	1 1/4"	1 1/2"	1 1/2"	2"
BLAST HOSE	1"	1 1/4"	1 1/4"	1 1/2"	1 1/2"
MEDIA ( lbs per hr)	560	900	1260	1750	2250

## 6.4 ADDITIONAL INFORMATION ON BLASTING PRODUCTIVITY

Air volume and pressure are very important. The blasting production rate will increase with higher blasting pressures and decrease with lower blasting pressures. The National Association of Corrosion Engineers' data suggests that for each 1 psi reduction in nozzle pressure, there is a 1.5% production loss. Pressure drop through a Schmidt blast unit is normally less than 1 psi, while blast units manufactured by some of our competitors have pressure losses as high as 12 psi resulting in an 18% loss of production. Air pressure loss can also be avoided by using the shortest possible hose of adequate size. The inside diameter of both the blast hose (other than whip hose) and the air hose should be approximately three times the diameter of the orifice in the blast nozzle. Standard Schmidt blast units are rated for a maximum pressure of 125 psi although high pressure units rated for 150 psi are available on request.

## **7.0 TROUBLE SHOOTING**

The following section covers procedures for solving problems that may arise during operation of the blasting equipment. Note that the below mentioned data may not all apply to your particular unit. The significance of the data is dependent on the control type and accessories furnished on the unit

### **7.1 Air Blast But No Abrasive**

- 7.1.1 The pot is empty
- 7.1.2 The abrasive in the pot is wet. Try closing the choke valve until some abrasive is pumped out. Operating the unit in the “choked” condition will allow the use of media that is too damp to flow properly, but it greatly accelerates wear in the metering valve. Continuous running in the choked condition also reduces productivity and therefore should be avoided if possible.
- 7.1.3 Foreign matter is plugging the abrasive metering valve. Try closing the choke valve and opening the abrasive metering valve momentarily to see if that will blow the obstruction out. If that does not work, then it will be necessary to de-pressurize the pot and remove the obstruction by hand.

### **7.2 Reduced Pressure At The Nozzle (with or without abrasive flow)**

- 7.2.1 Insufficient air compressor output (see air requirements in section 6.0).
- 7.2.2 Air hose too small.
- 7.2.3 Abrasive metering valve adjustment open too far.
- 7.2.4 Pop-up not seating properly.
- 7.2.5 Choke valve partially closed.
- 7.2.6 Trash may partially plug the nozzle orifice.

### **7.3 Unit Is Slow To Turn On Or Will Not Turn On**

- 7.3.1 Air hose is too small. The air hose diameter should be at least three (3) times the nozzle diameter. (Symptom: Air will blow out of the blowdown but the pot does not pressurize.)
- 7.3.2 Insufficient air compressor output. (Symptom: Air will blow out of the blowdown but the pot does not pressurize.)
- 7.3.3 Check quick connect couplings on control hoses to be sure they are engaged properly.
- 7.3.4 Control hoses are leaking. (Symptom: The pot will turn on slowly or does not turn on at all.)
- 7.3.5 Control hoses are plugged. If the black hose is disconnected from the cylinder of the combo valve, there should be air pressure whenever the deadman is depressed.
- 7.3.6 Worn piston seal in the combo valve. (Symptom: Air will blow out of the brass breather vent on the combo valve.)
- 7.3.7 Deadman is plugged. (Symptom: Only a weak air signal, or none at all will come from the deadman when the black hose is disconnected.)
- 7.3.8 Defective cartridge in the deadman valve. (Symptom: Air will blow out of the deadman whenever the lever is depressed.)
- 7.3.9 *On normally closed systems only:* Defective diaphragm in the automatic air valve.
- 7.3.10 *On normally closed systems only:* Defective diaphragm in the blowdown valve.

### **7.4 Unit Is Slow To Turn Off Or Will Not Turn Off**

- 7.4.1 Twinline hoses are crossed. The left part of the deadman (when viewed from the hose connection end) should be connected to the combo valve using the black hose.
- 7.4.2 The lower rod guide seal is defective. If you disconnect the black hose from the 1/8" port on the combo valve, air should not blow out of the combo valve.
- 7.4.3 The lower rod guide o-ring is damaged or missing.
- 7.4.4 The lower rod guide is installed upside down. (Symptom: The pot turns on as soon as the air supply is turned on.)
- 7.4.5 The valve plug in the combo valve is defective and will not seal.
- 7.4.6 A bleeder type deadman valve has been installed.

### **7.5 Unit Turns On Accidentally**

- 7.5.1 The lever on the deadman valve is worn out.
- 7.5.2 The safety button on the deadman valve is missing.
- 7.5.3 A bleeder type valve has been installed. A bleeder type deadman valve is unsafe because a piece of dirt from the air hose can plug the hole in the deadman and cause the blast unit to turn on.